

SAL24105

(3.5-4.5/24-105) (24-105mm F3.5-4.5)

SERVICE MANUAL

[Ver. 1.5 2008.03](#)

[Revision History](#)

[How to use
Acrobat Reader](#)

Revised-4

Replace the previously issued
SERVICE MANUAL 9-852-111-14
with this Manual.



*US Model
Canadian Model
AEP Model
Chinese Model*

Link

[• SPECIFICATIONS](#)

[• DISASSEMBLY](#)

[• ADJUSTMENTS](#)

[• SERVICE NOTE](#)

[• REPAIR PARTS LIST](#)

- [• About the Lens Test Projector and Finished Inspection JIG](#)

LENS FOR DSLR CAMERA

SONY[®]



SPECIFICATIONS

- This lens is equipped with a distance encoder. The distance encoder allows more accurate measurement (ADI) by using a flash for ADI.
- Depending on the lens mechanism, the focal length may change with any change of the shooting distance. The focal length assumes the lens is focused at infinity.

Equivalent 35mm-format focal length *1 (mm)

36-157.5

*1 The value for equivalent 35mm-format focal length is based on Digital Single Lens Reflex Cameras equipped with an APS-C sized image sensor.

Lens groups elements

11-12

Angle of view 1 *2

84°-23°

Angle of view 2 *2

61°-15°

*2 The value of angle of view 1 is based on 35mm-format cameras, and that of angle of view 2 is based on Digital Single Lens Reflex Cameras equipped with an APS-C sized image sensor.

Minimum focus (m (feet)) *3

0.5 (1.6)

*3 Minimum focus is the shortest distance from the image sensor to the subject.

Maximum magnification (×)

0.18

Minimum f-stop

f/22-27

Filter diameter (mm)

62

Dimensions (maximum diameter × height) (mm (in.))

Approx. 71 × 69 (2 13/16 × 2 11/16)

Mass (g (oz.))

Approx. 395 (13 15/16)

Included items

Lens (1), Front lens cap (1), Rear lens cap (1), Lens hood (1), Set of printed documentation

Designs and specifications are subject to change without notice.

TABLE OF CONTENTS

<i>Section</i>	<i>Title</i>	<i>Page</i>
1.	SERVICE NOTE	
1-1.	Chemicals	1-1
1-2.	Exterior Parts	1-1
1-3.	Unleaded Solder	1-1
1-4.	Safety Check-out	1-2
1-5.	Troubleshooting	1-3
2.	DISASSEMBLY	
2-1.	Disassembly	2-2
3.	REPAIR PARTS LIST	
3-1.	Exploded Views	3-1
3-2.	Supplied Accessories	3-7
4.	ADJUSTMENTS	
4-1.	Preparations	4-1
4-2.	Aperture Diameter Check/Adjustment	4-13
4-3.	Projective Resolving Power Check/Adjustment	4-18
4-4.	Focus-shift/Flange Back (f'F) and Optical Axis Check/Adjustment	4-22
4-5.	Focus-shift (by Zooming) Check/Adjustment	4-25
4-6.	Focus Scale Plate, Position Adjustment	4-26
4-7.	Focus-shift Check/Adjustment (Aperture (Amount of Spherical Aberration))	4-27
4-8.	Lens ROM Check	4-28
4-9.	Zoom Brush Position Check/Adjustment and Pattern Check	4-30
4-10.	Focus Brush Position Check/Adjustment and Pattern Check	4-38

1. SERVICE NOTE

1-1. Chemicals

Some chemicals used for servicing are highly volatile.

Their evaporation caused by improper management affects your health and environment, and wastes resources.

Manage the chemicals carefully as follows.

- Store chemicals sealed in a specific place to prevent from exposure to high temperature or direct sunlight.
- Avoid dividing chemicals into excessive numbers of small containers to reduce natural evaporation.
- Keep containers sealed to avoid natural evaporation when chemicals are not in use.
- Avoid using chemicals as much as possible. When using chemicals, divide only required amount to a small plate from the container and use up it.

1-2. Exterior Parts

Be careful to the following points for exterior parts used in this unit.

- Use a piece of cleaning paper or cleaning cloth for cleaning exterior parts. Avoid using chemicals.
Even if you have to use chemicals to clean heavy dirt, don't use paint thinner, ketone, nor alcohol.
- Insert the specific screws vertically to the part when installing a exterior part.
Be careful not to tighten screws too much.

1-3. Unleaded Solder

This unit uses unleaded solder.

Boards requiring use of unleaded solder are printed with the lead free mark (LF) indicating the solder contains no lead.

(**Caution:** Some printed circuit boards may not come printed with the lead free mark due to their particular size.)

: LEAD FREE MARK

Be careful to the following points to solder or unsolder.

- Set the soldering iron tip temperature to 350 °C approximately.
If cannot control temperature, solder/unsolder at high temperature for a short time.
Caution: The printed pattern (copper foil) may peel away if the heated tip is applied for too long, so be careful!
Unleaded solder is more viscous (sticky, less prone to flow) than ordinary solder so use caution not to let solder bridges occur such as on IC pins, etc.
- Be sure to control soldering iron tips used for unleaded solder and those for leaded solder so they are managed separately. Mixing unleaded solder and leaded solder will cause detachment phenomenon.

1-4. SAFETY CHECK-OUT

After correcting the original service problem, perform the following safety checks before releasing the set to the customer.

1. Check the area of your repair for unsoldered or poorly-soldered connections. Check the entire board surface for solder splashes and bridges.
2. Check the interboard wiring to ensure that no wires are “pinched” or contact high-wattage resistors.
3. Look for unauthorized replacement parts, particularly transistors, that were installed during a previous repair. Point them out to the customer and recommend their replacement.
4. Look for parts which, through functioning, show obvious signs of deterioration. Point them out to the customer and recommend their replacement.
5. Check the B+ voltage to see it is at the values specified.
6. Flexible Circuit Board Repairing
 - Keep the temperature of the soldering iron around 270 °C during repairing.
 - Do not touch the soldering iron on the same conductor of the circuit board (within 3 times).
 - Be careful not to apply force on the conductor when soldering or unsoldering.

CAUTION

Danger of explosion if battery is incorrectly replaced.
Replace only with the same or equivalent type.

SAFETY-RELATED COMPONENT WARNING!!

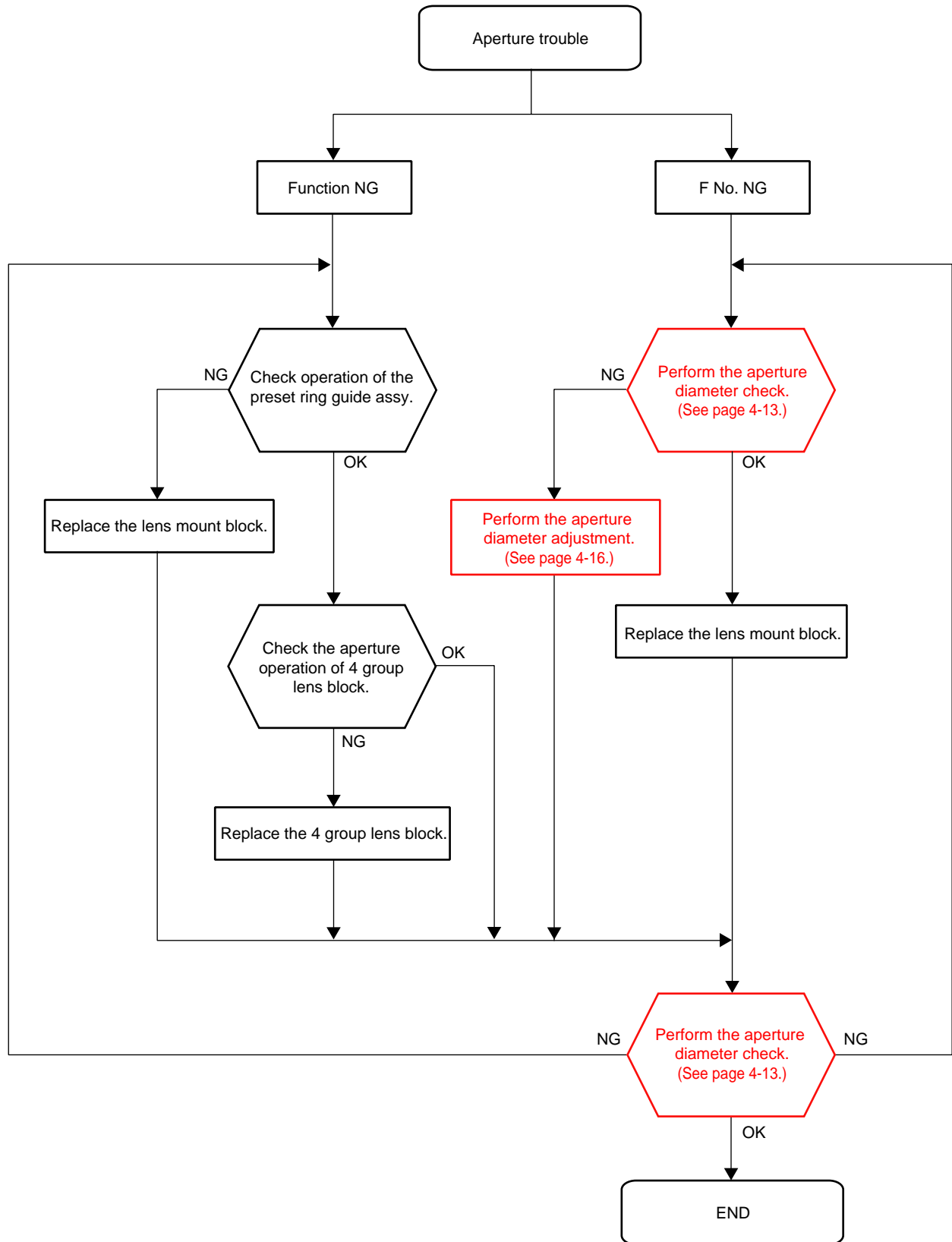
COMPONENTS IDENTIFIED BY MARK \triangle OR DOTTED LINE WITH MARK \triangle ON THE SCHEMATIC DIAGRAMS AND IN THE PARTS LIST ARE CRITICAL TO SAFE OPERATION. REPLACE THESE COMPONENTS WITH SONY PARTS WHOSE PART NUMBERS APPEAR AS SHOWN IN THIS MANUAL OR IN SUPPLEMENTS PUBLISHED BY SONY.

ATTENTION AU COMPOSANT AYANT RAPPORT À LA SÉCURITÉ!

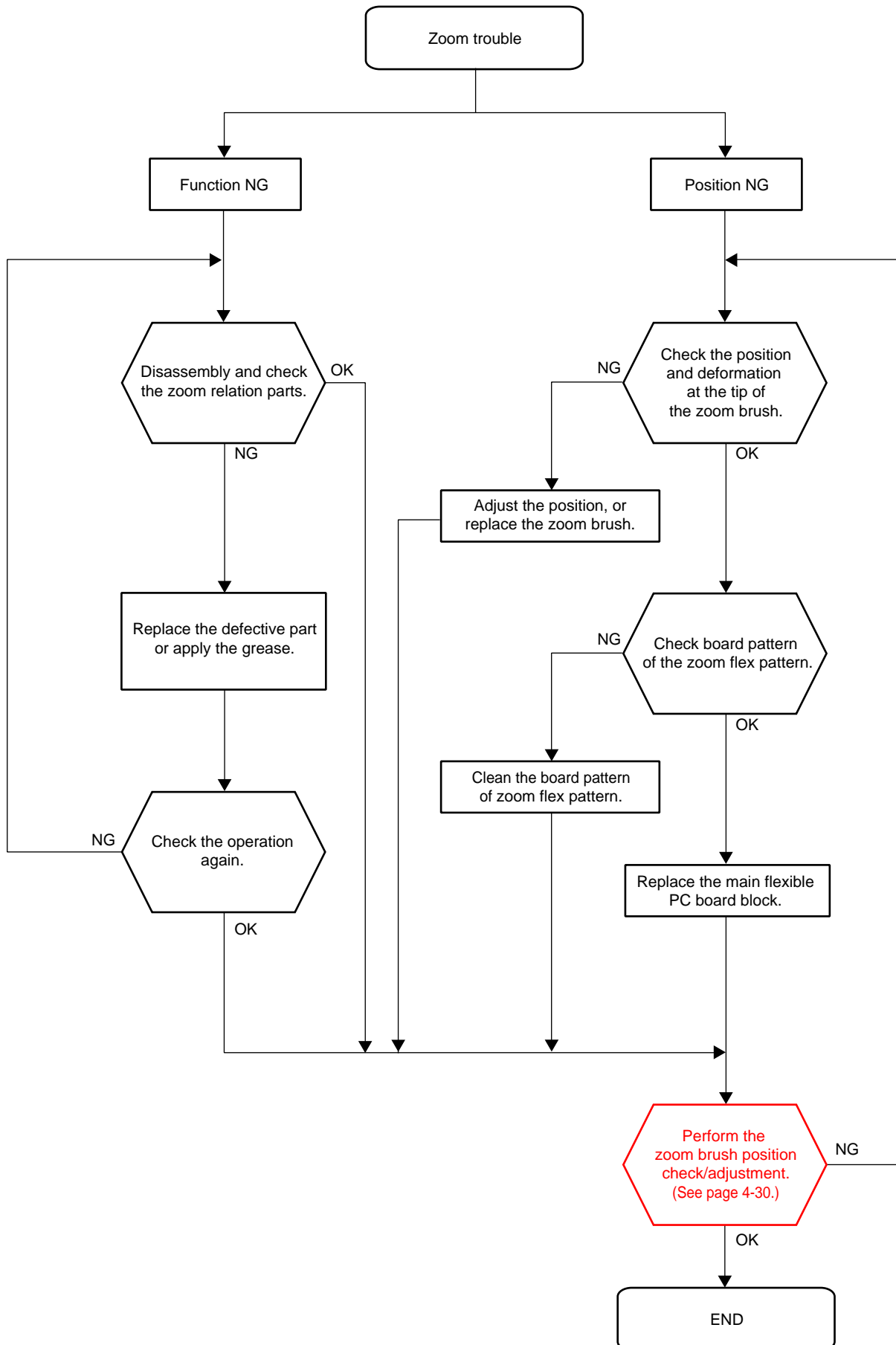
LES COMPOSANTS IDENTIFÉS PAR UNE MARQUE \triangle SUR LES DIAGRAMMES SCHÉMATIQUES ET LA LISTE DES PIÈCES SONT CRITIQUES POUR LA SÉCURITÉ DE FONCTIONNEMENT. NE REMPLACER CES COMPOSANTS QUE PAR DES PIÈSES SONY DONT LES NUMÉROS SONT DONNÉS DANS CE MANUEL OU DANS LES SUPPLÉMENTS PUBLIÉS PAR SONY.

1-5. TROUBLESHOOTING

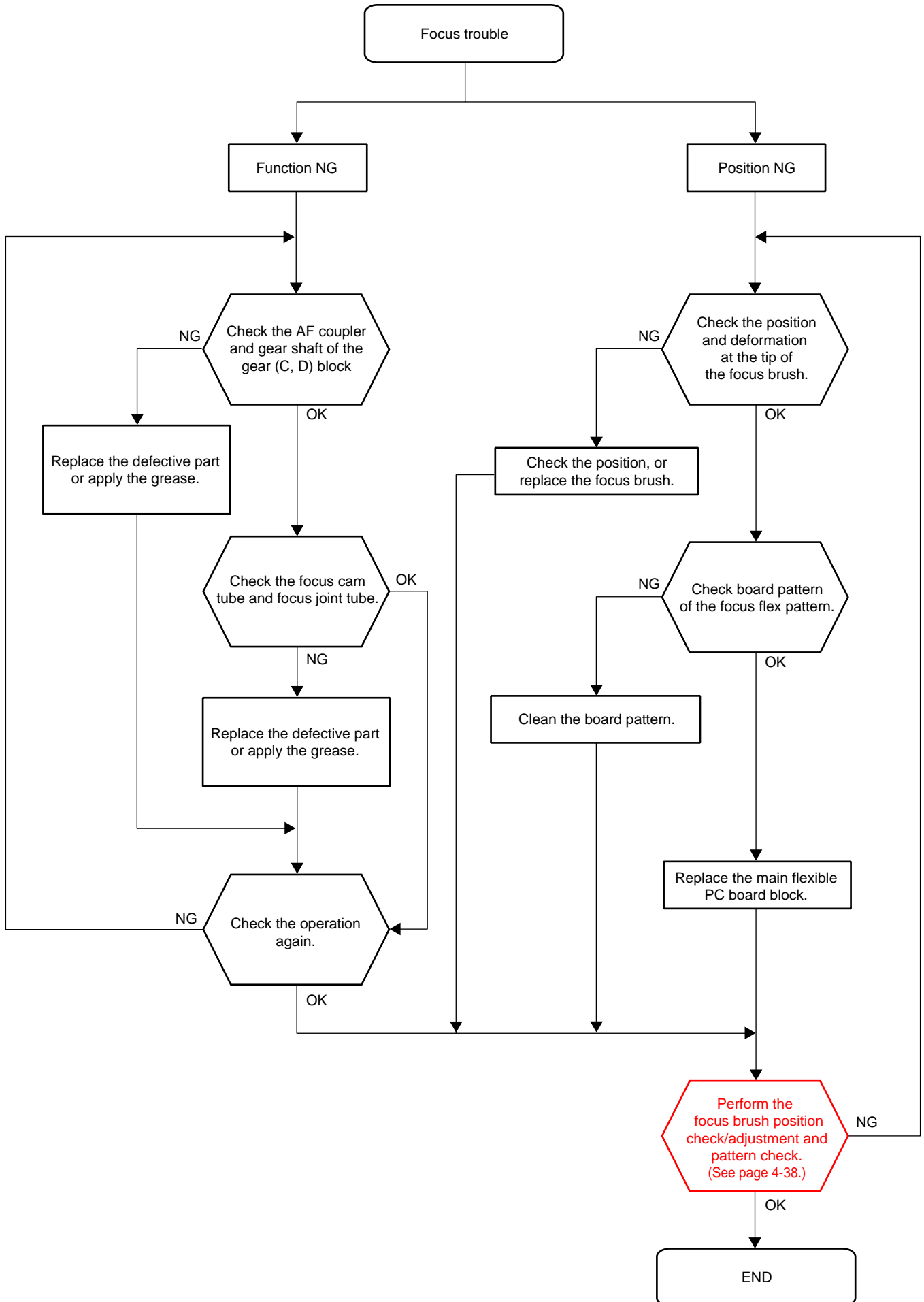
1-5-1. Aperture Trouble



1-5-2. Zoom Trouble



1-5-3. Focus Trouble

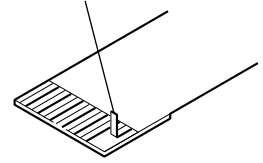


2. DISASSEMBLY

NOTE FOR REPAIR

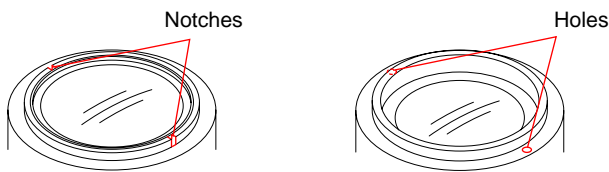
- Make sure that the flat cable and flexible board are not cracked or bent at the terminal. Do not insert the cable insufficiently nor crookedly.
- When remove a connector, don't pull at wire of connector. It is possible that a wire is snapped.
- When installing a connector, don't press down at wire of connector. It is possible that a wire is snapped.
- Do not apply excessive load to the gilded flexible board.

Cut and remove the part of gilt which comes off at the point. (Be careful or some pieces of gilt may be left inside)

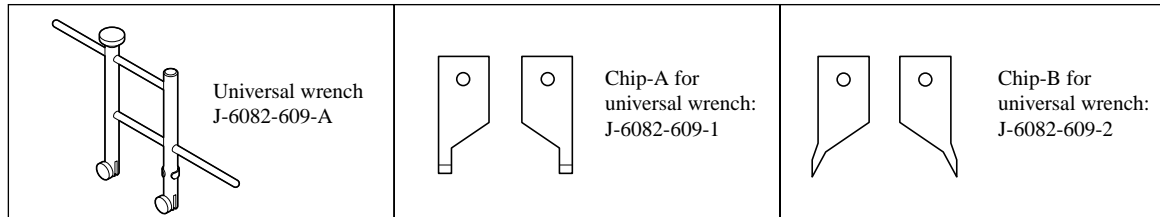


UNIVERSAL WRENCH

In case of the following notches or holes are located in the lens block, etc during disassembling/ assembling the lens, Use the universal wrench.



How to Use

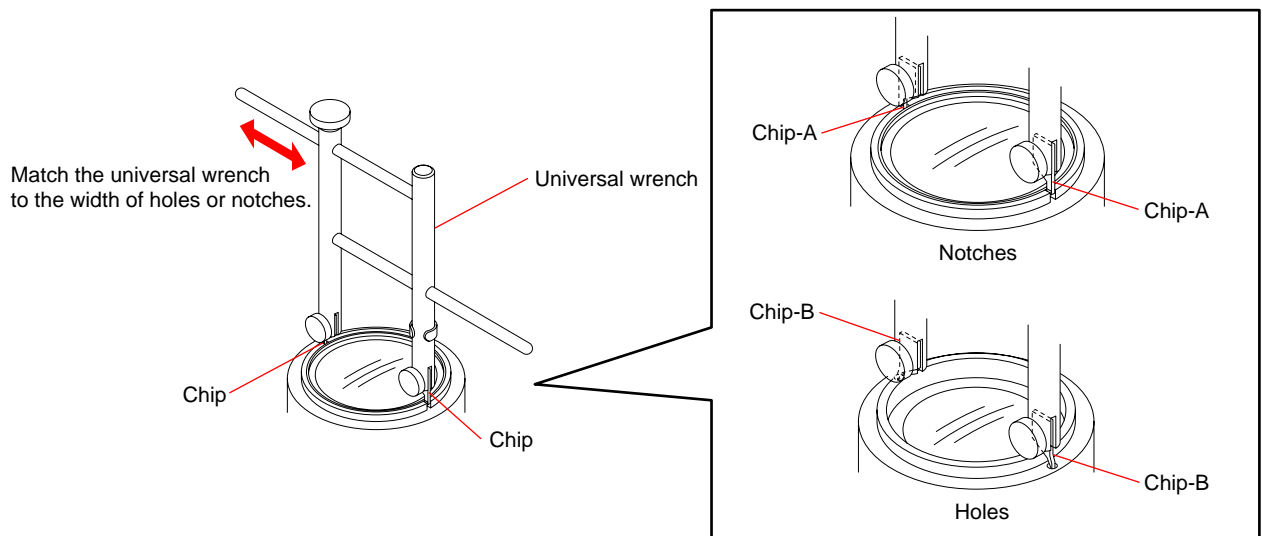


Attach the chip-A or chip-B to the universal wrench.

For the notches: chip-A

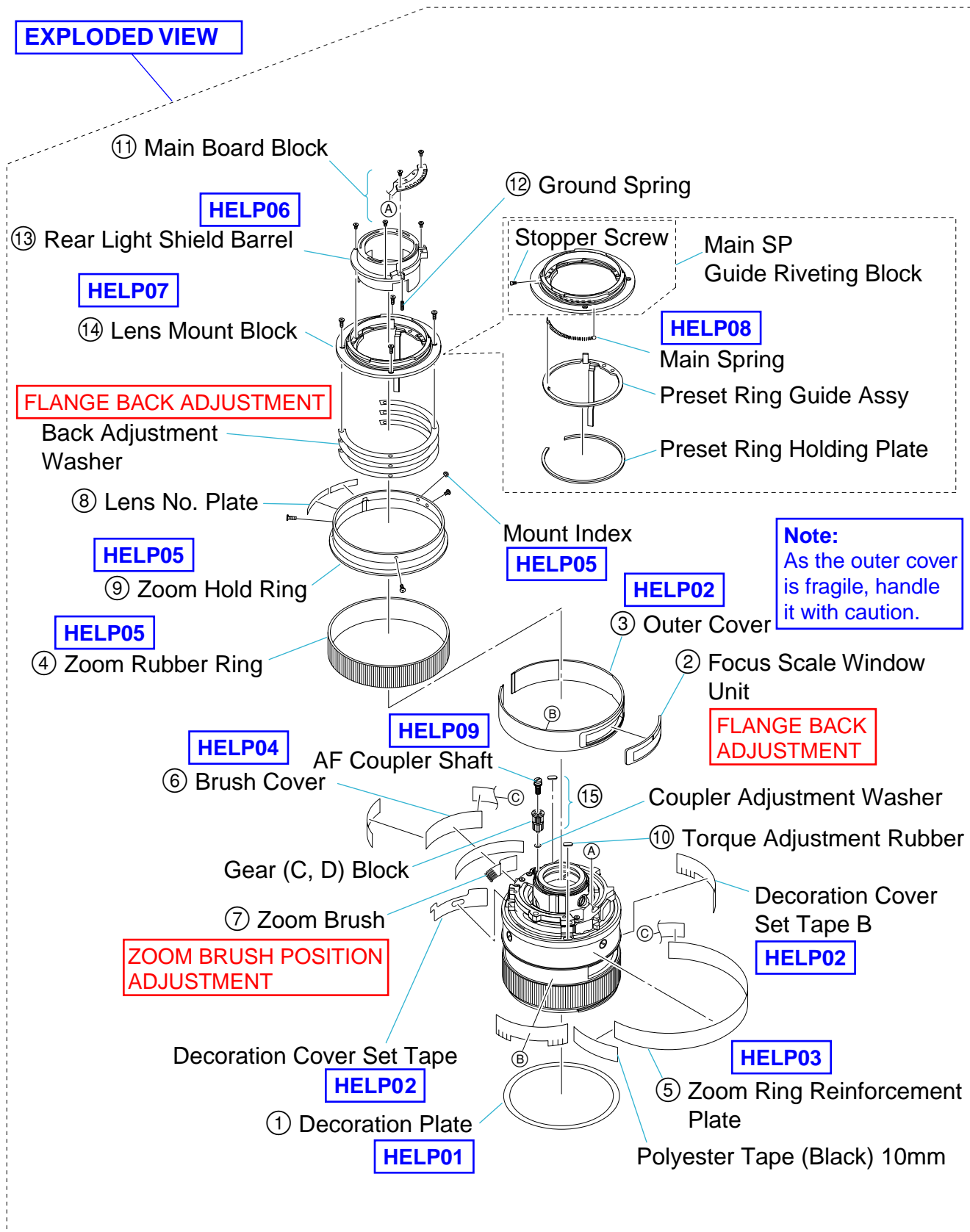
For the holes: chip-B

Match the universal wrench to the holes or notches of the lens block, etc.

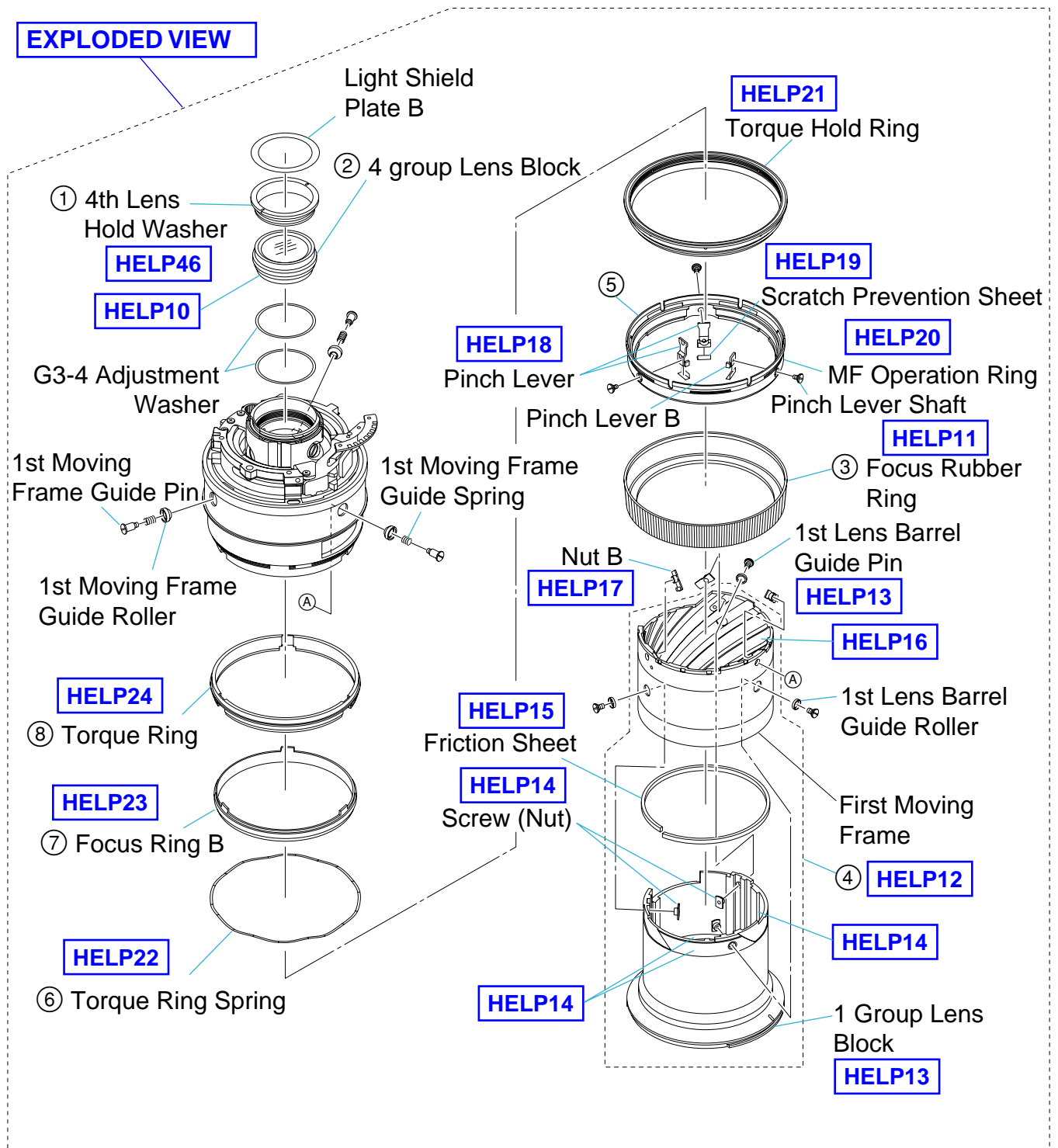


2-1. DISASSEMBLY

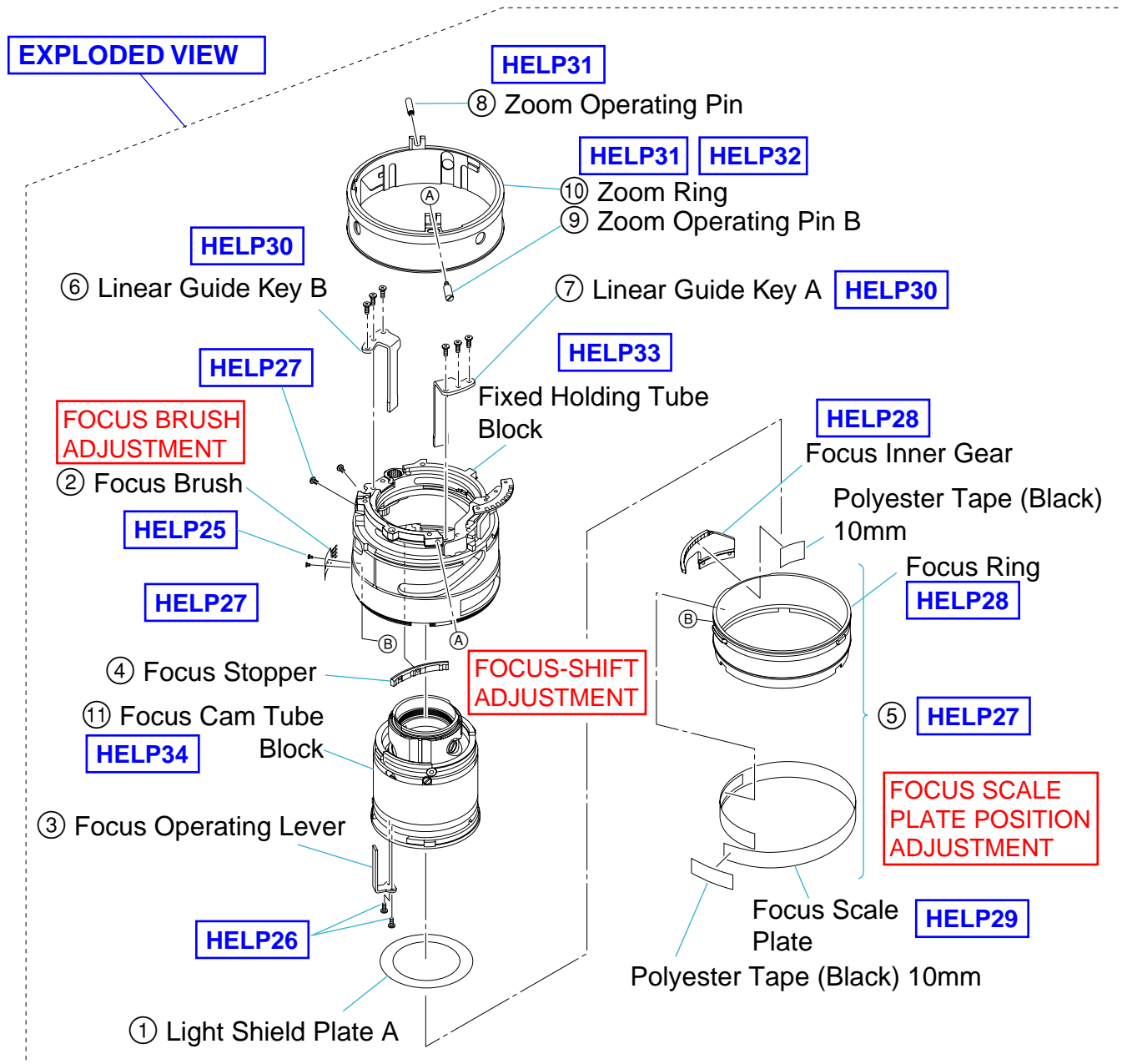
2-1-1. LENS MOUNT BLOCK AND OUTER COVER



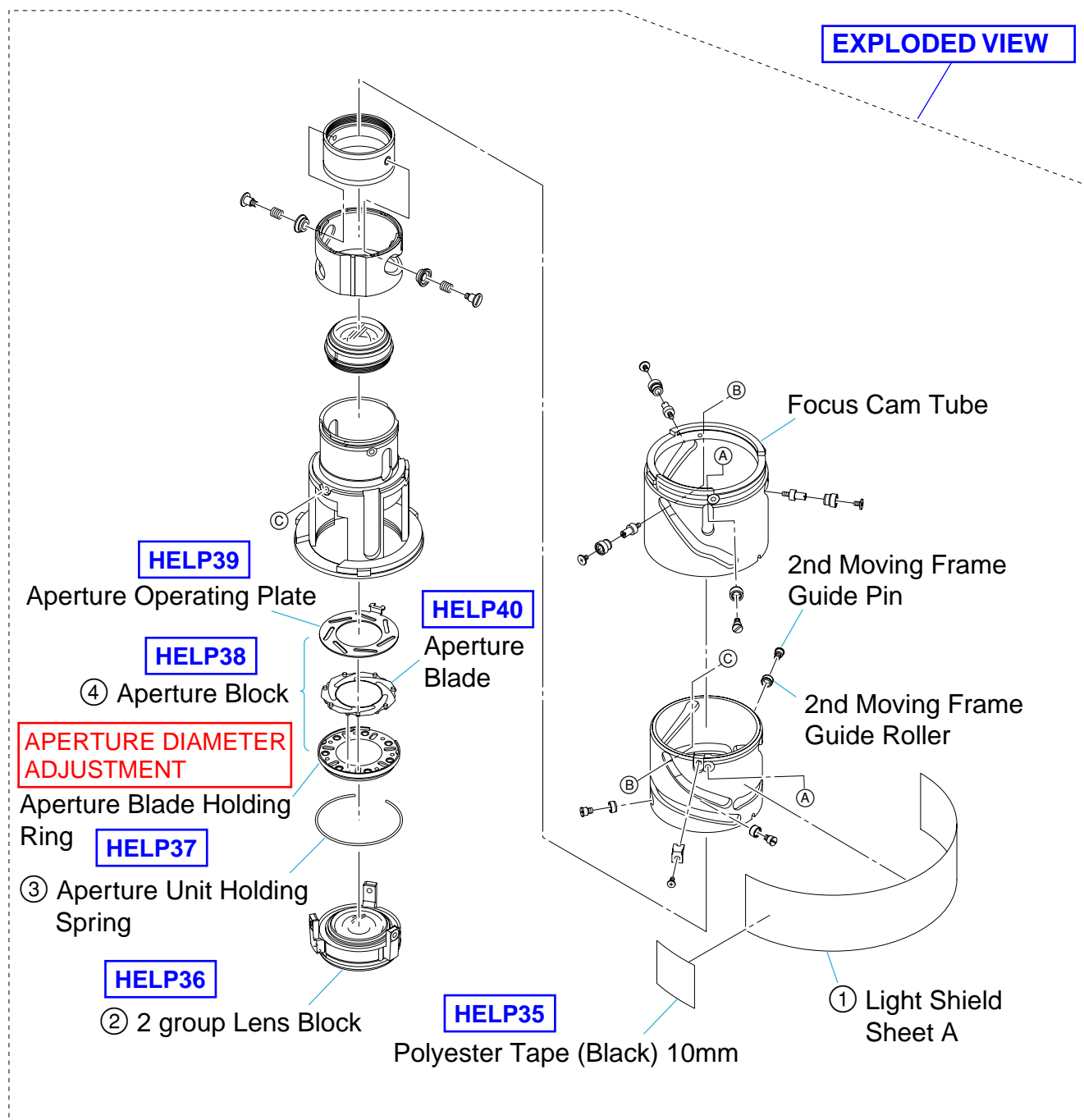
2-1-2. FIRST MOVING FRAME AND 1ST LENS BARREL HOLDER



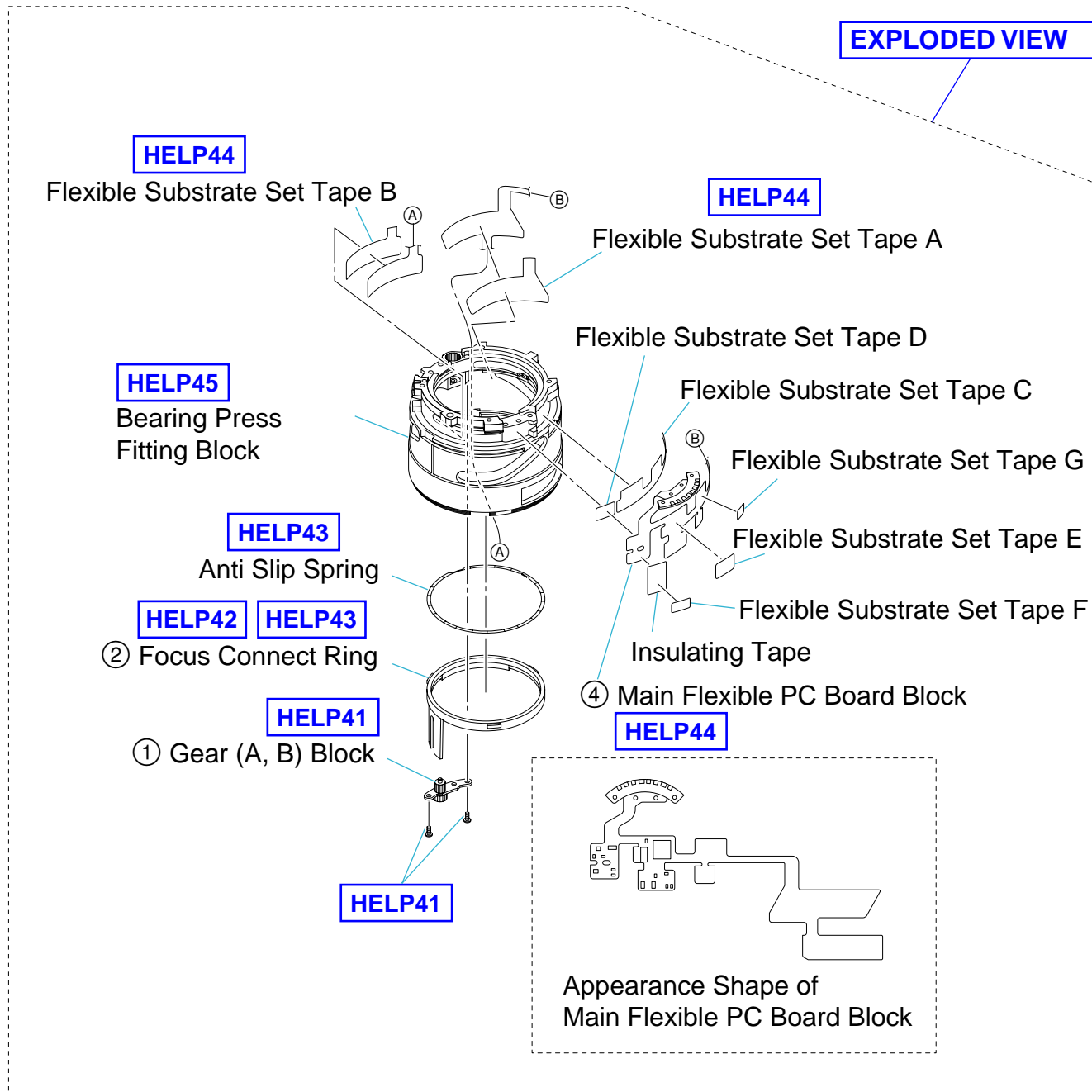
2-1-3. FOCUS CAMTUBE BLOCK, ZOOM RING AND FOCUS RING



2-1-4. APERTURE BLADE BLOCK AND 2 GROUP LENS BLOCK



2-1-5. MAIN FLEXIBLE PC BOARD BLOCK AND FOCUS CONNECT RING

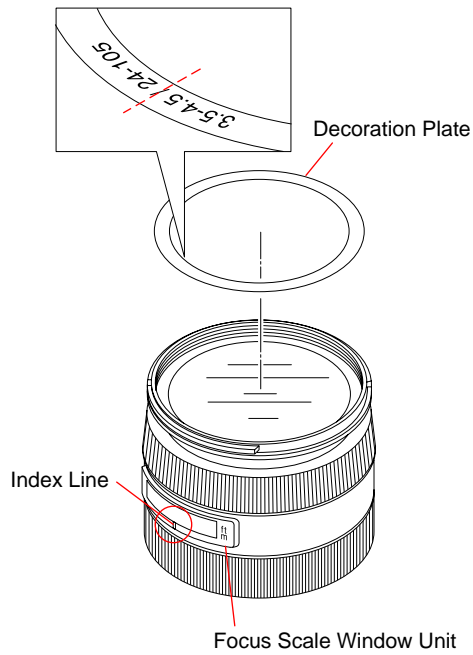


HELP

Note for assembling and grease applying positions are shown.

HELP01

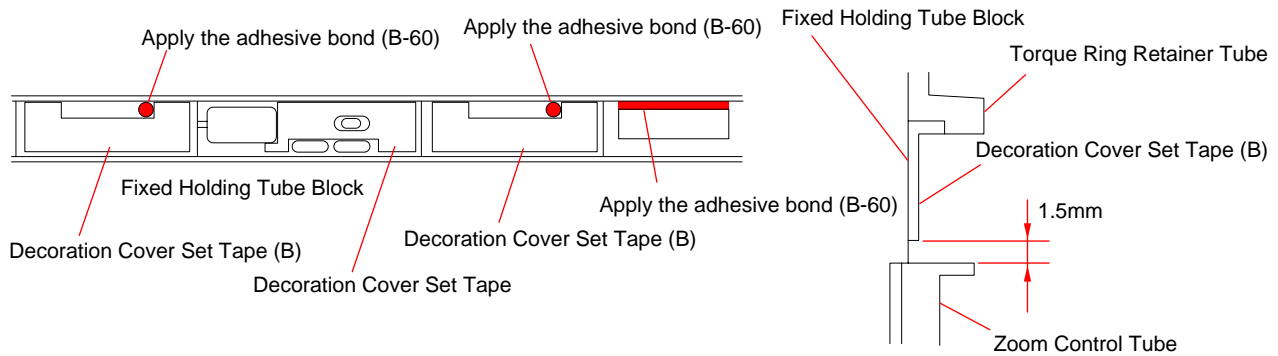
Affix the decoration plate, aligning its “/” of “3.5 - 4.5/24 - 105” with the index line of focus scale window unit.



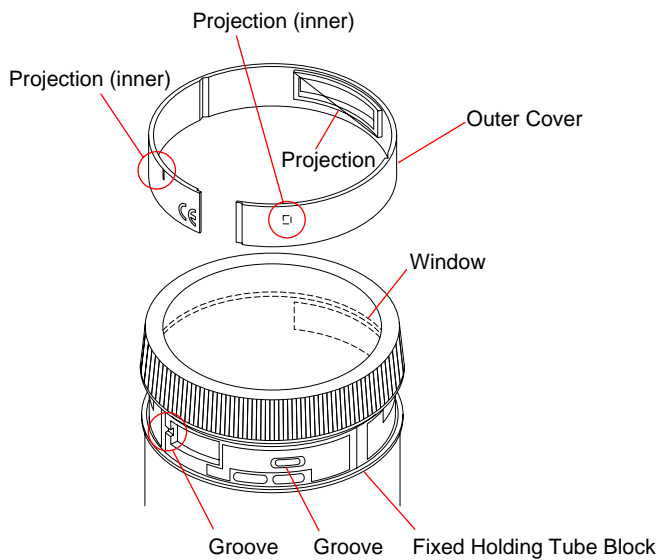
HELP02

Adhesive bond (B-60): J-6082-616-A

1. Affix the decoration cover set tape and decoration cover set tape (B) to the position shown in the figure.
Affix the decoration cover set tape to the fixed holding tube block and torque ring retainer tube.
2. Apply the adhesive bond (B-60) to the specified portions of fixed holding tube block and torque ring retainer tube.



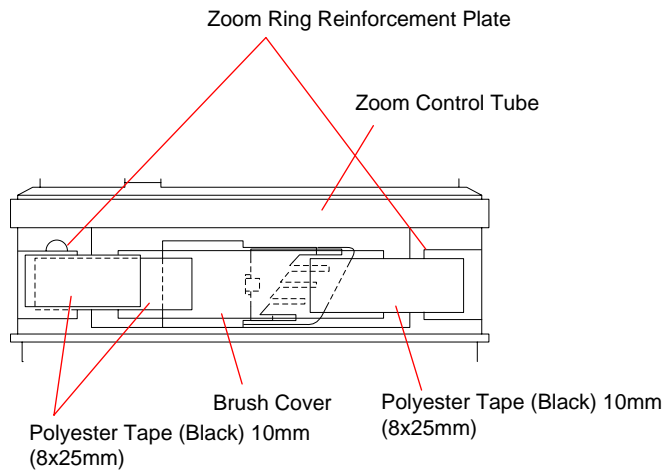
3. Affix the outer cover to the fixed holding tube block, inserting its projections in the grooves and window of fixed holding tube block.



HELP03

Cut the polyester tapes (black) 10mm as instructed in the figure.

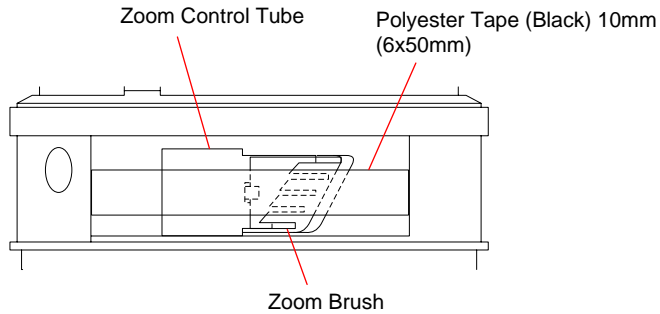
Affix the brush cover and zoom ring reinforcement plate with the polyester tapes (black) 10mm as shown in the figure.



HELP04

After adjusting the zoom brush position adjustment, affix the polyester tapes (black) 10mm cut as instructed to the position shown in the figure.

Note: For zoom brush position adjustment, refer to P.4-30.



HELP05

Adhesive bond (LOCTITE 460)

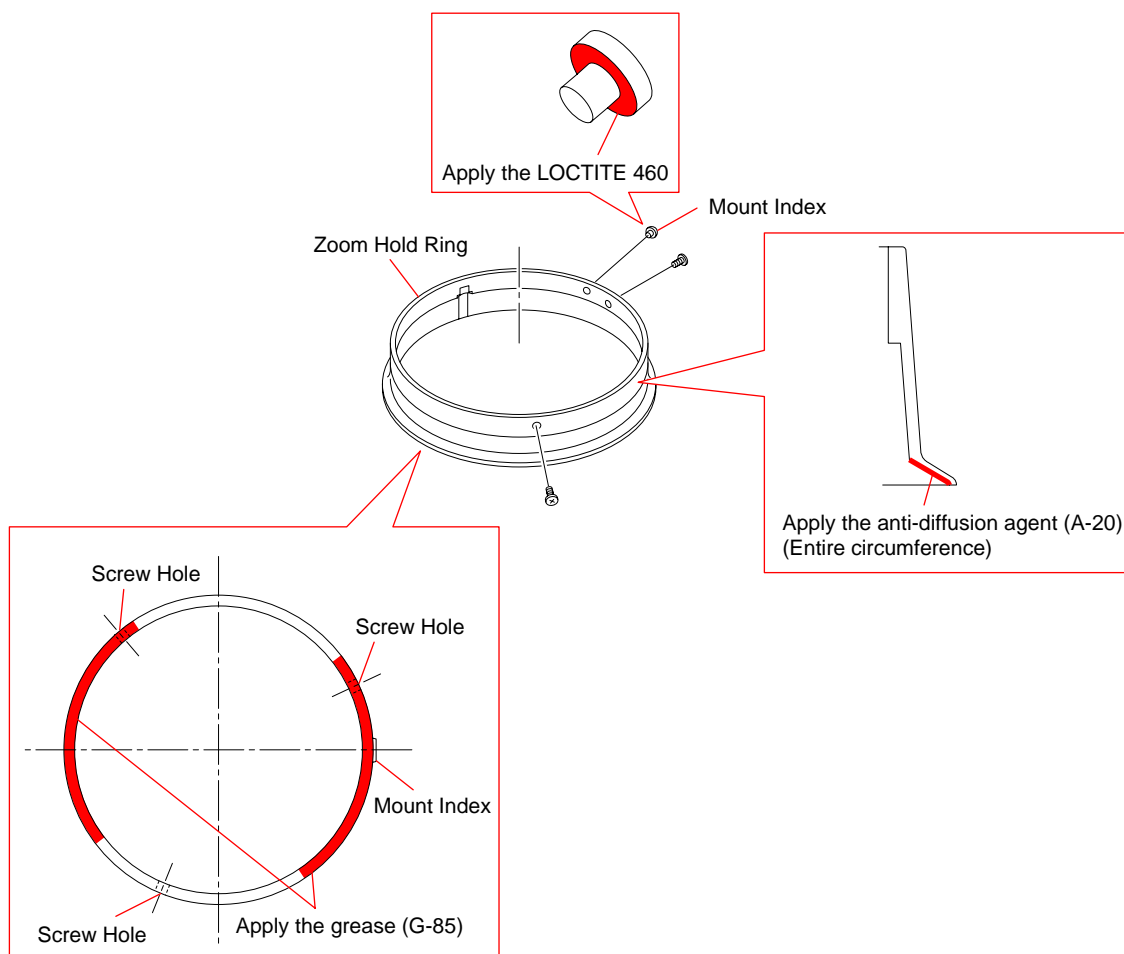
Note: Use the adhesive bond (LOCTITE 460) or the equivalent.

Do not use other adhesive bond such as the instantaneous glue that becomes whitish after dried.

Anti-diffusion agent (A-20): J-6082-611-A

Grease (G-85): J-6082-626-A

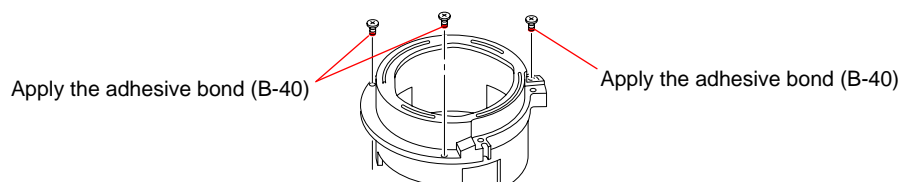
1. Apply the adhesive bond (LOCTITE 460) to the indicated portions of mount index and insert it in the specified hole of zoom hold ring.
2. Apply the anti-diffusion agent (A-20) to the entire circumference of indicated portion of zoom hold ring.
3. Apply the grease (G-85) to the indicated portions (two locations) of zoom hold ring.



HELP06

Adhesive bond (B-40): J-6082-614-A

Apply the adhesive bond (B-40) to the tips of three screws and tighten them as shown in the figure.



SAL24105 (3.5-4.5/24-105) (24-105mm F3.5-4.5)

HELP07

Adhesive bond (LOCTITE 460)

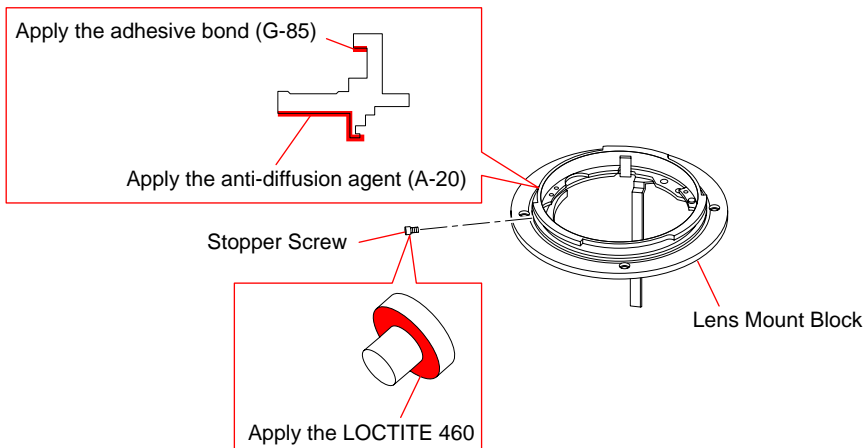
Note: Use the adhesive bond (LOCTITE 460) or the equivalent.

Do not use other adhesive bond such as the instantaneous glue that becomes whitish after dried.

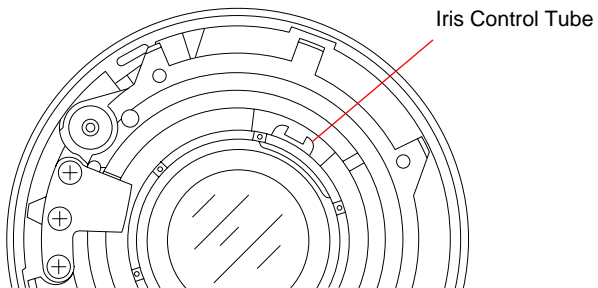
Grease (G-85): J-6082-626-A

Anti-diffusion agent (A-20): J-6082-611-A

1. Apply the grease (G-85) to the indicated portions (three locations) of lens mount block.
2. Apply the anti-diffusion (A-20) to the entire circumference of indicated portion of lens mount block.



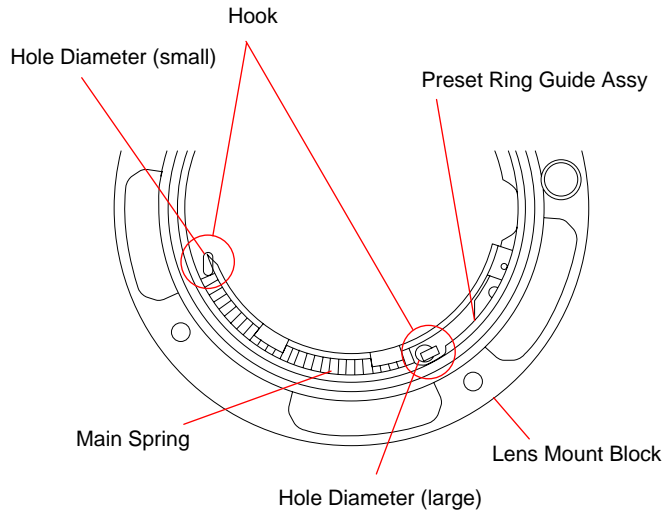
3. Insert the preset ring guide assembly in the iris control plate and attach the main SP guide riveting block.



HELP08

Hook the main spring to the lens mount block and preset ring guide assy as shown in the figure.

Note: Hook one where hole diameter of coil of main spring is small for the lens mount block, hook one where hole diameter of coil of main spring is large for the preset ring guide assy.

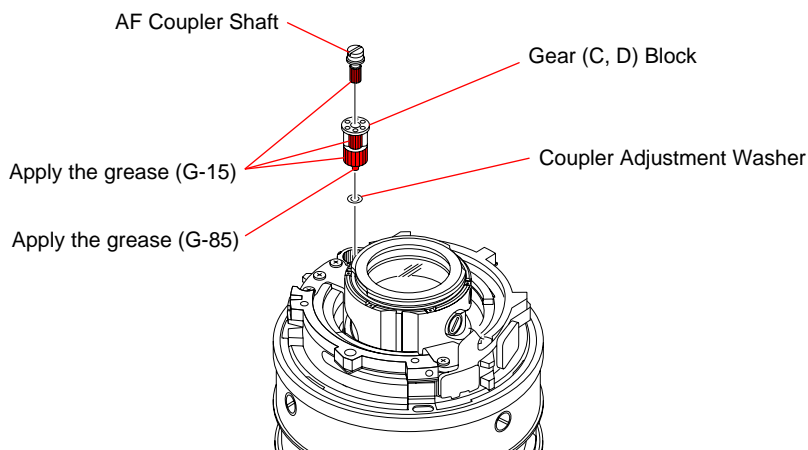


HELP09

Grease (G-15): J-6082-619-A

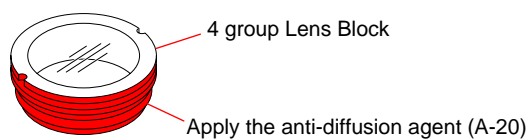
Grease (G-85): J-6082-626-A

1. Apply the grease (G-15) to the indicated portions of AF coupler shaft and gear (C, D) block.
2. Apply the grease (G-85) to the shaft of gear (C, D) block.



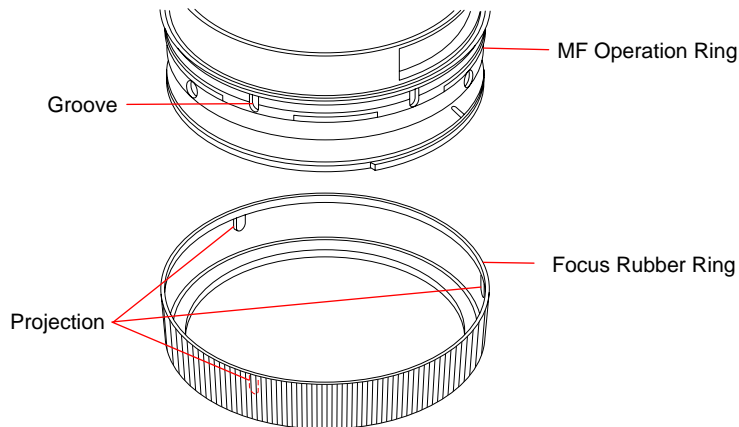
HELP10

Apply the anti-diffusion agent (A-20) to the entire circumference of indicated portion of 4 group lens block.



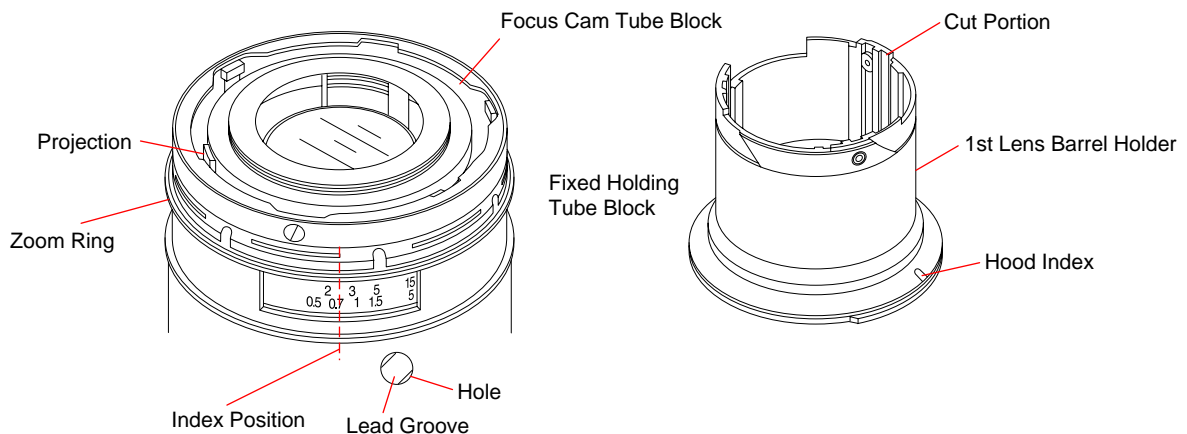
HELP11

Attach three projections of focus rubber ring along the groove of MF operation ring.

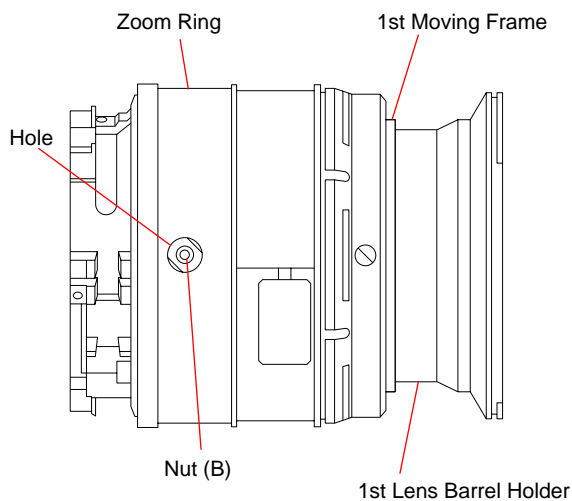


HELP12

1. Align the lead groove of fixed holding tube with the hole of zoom ring by rotating the zoom ring.
2. Align the index (center near the distance scale window) of fixed holding tube block with the hood index of 1st lens barrel holder. Then, insert the 1st lens barrel holder in the focus cam tube block, aligning the cut portion of 1st lens barrel holder with the projection of focus cam tube block.



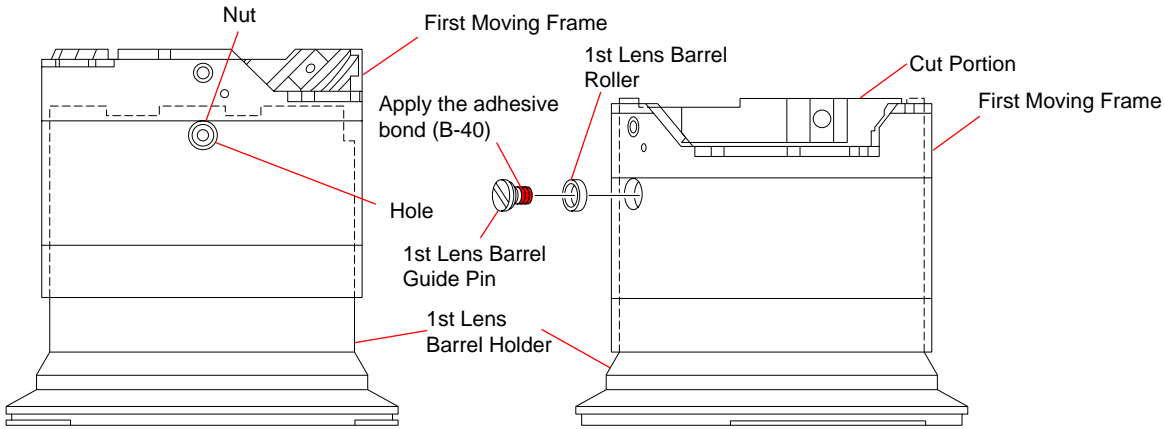
3. Attach the 1st lens barrel holder, aligning the hole of zoom ring with the nut (B) by rotating the first moving frame.



HELP13

Adhesive bond (B-40): J-6082-614-A

Attach the 1st lens barrel roller and 1st lens barrel guide pin, aligning the nut with the hole of first moving frame (Align the 1st lens barrel holder with the cut portion of first moving frame.).



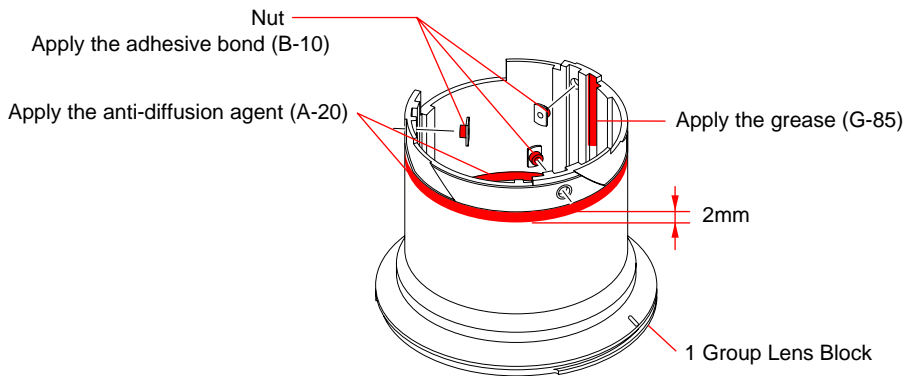
HELP14

Adhesive bond (B-10): J-6082-612-A

Grease (G-85): J-6082-626-A

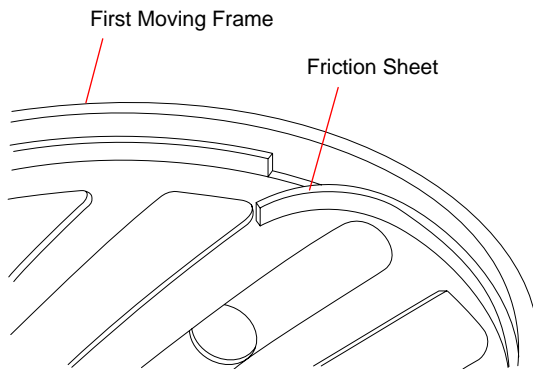
Anti-diffusion agent (A-20): J-6082-611-A

1. Apply the grease (G-85) to the indicated portion (1/2 of lead groove of indicated portion at inner side) of 1 group lens block.
2. Apply the adhesive bond (B-10) to three nuts and insert them in the 1 group lens block.
3. Apply the anti-diffusion agent (A-20) to the indicated portion of 1 group lens block.



HELP15

Affix the friction sheet to the position shown in the figure.

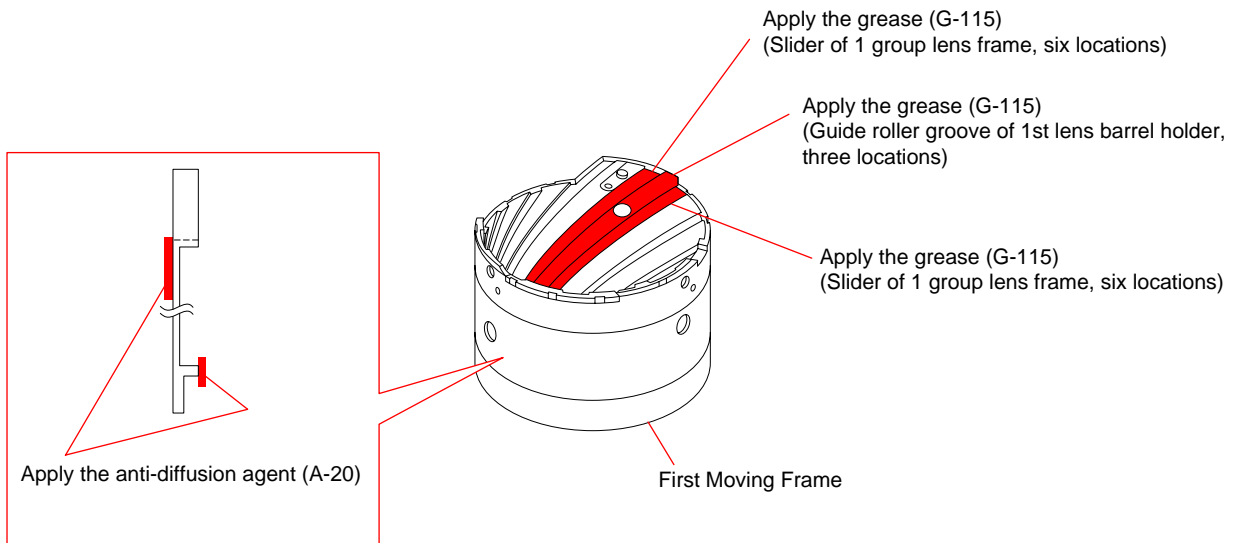


HELP16

Anti-diffusion agent (A-20): J-6082-611-A

Grease (G-115): J-6082-617-A

1. Apply the anti-diffusion agent (A-20) to the indicated portion (entire circumference) of first moving frame.
2. Apply the anti-diffusion agent (A-115) to the indicated portion (three locations) of first moving frame.



HELP17

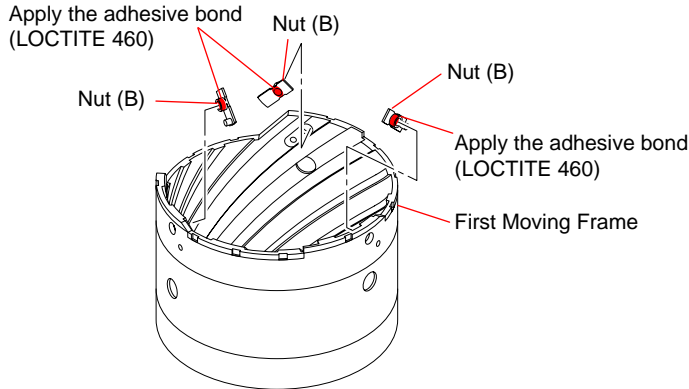
Adhesive bond (LOCTITE 460)

Note: Use the adhesive bond (LOCTITE 460) or the equivalent.

Do not use other adhesive bond such as the instantaneous glue that becomes whitish after dried.

Adhesive bond (B-40): J-6082-614-A

Apply the adhesive bond (LOCTITE 460) to the nut (B) and insert them in the specified holes of first moving frame. (Three locations)



HELP18

Adhesive bond (B-40): J-6082-614-A

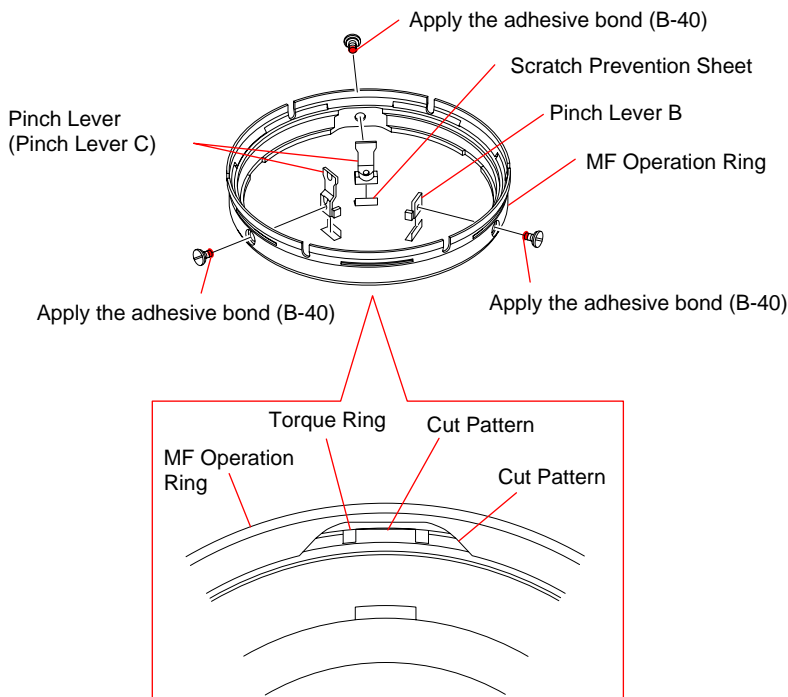
1. Align the cut portion of MF operation ring with the cut portion of torque ring by rotating the MF operation ring.
2. Align the pinch lever (or pinch lever C) and pinch lever B with the cut portion of torque ring, and insert the pinch lever rotation shafts.

Note:

- Replace the pinch lever C, in case focus clutch mechanism runs idle the pinch lever.
- In case use pinch lever C, replace with two it.

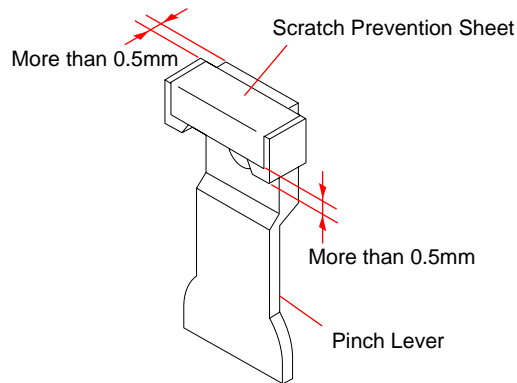
3. Apply the adhesive bond (B-40) to the pinch lever rotary shaft, and tighten them.

Note: In case use pinch lever C, tip of the pinch lever rotary shaft is black.



HELP19

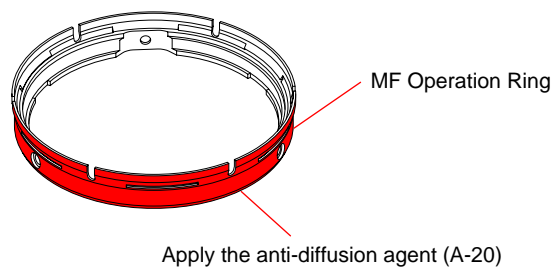
Affix the scratch prevention sheet to the pinch lever (pinch lever C) and pinch lever B as shown in the figure.



HELP20

Anti-diffusion agent (A-20): J-6082-611-A

Apply the anti-diffusion agent (A-20) to the entire outer circumference of MF operation ring.



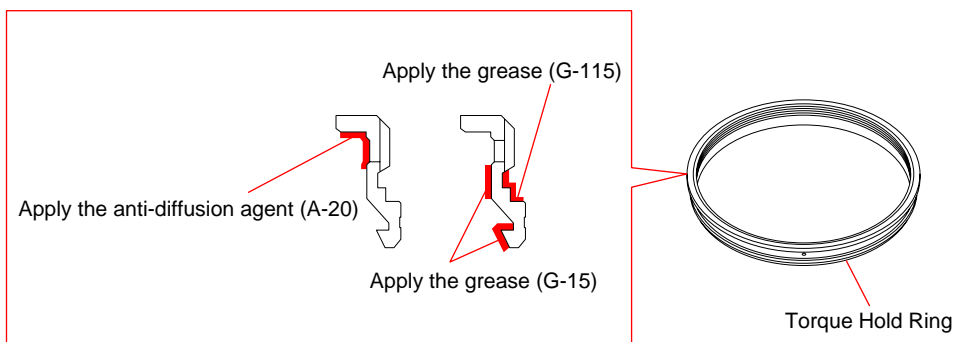
HELP21

Anti-diffusion agent (A-20): J-6082-611-A

Grease (G-15): J-6082-616-A

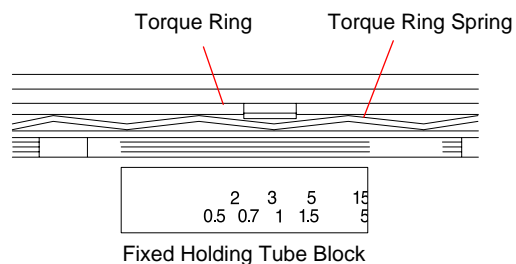
Grease (G-115): J-6082-627-A

1. Apply the anti-diffusion agent (A-20) to the indicated portion (entire circumference) of torque hold ring.
2. Apply the grease (G-15) and grease (G-115) to the indicated portion (entire circumference) of torque hold ring.



HELP22

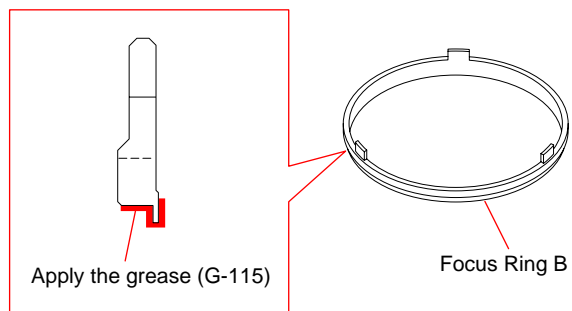
Attach the securely the torque ring spring A or torque ring spring B to the position shown in figure.



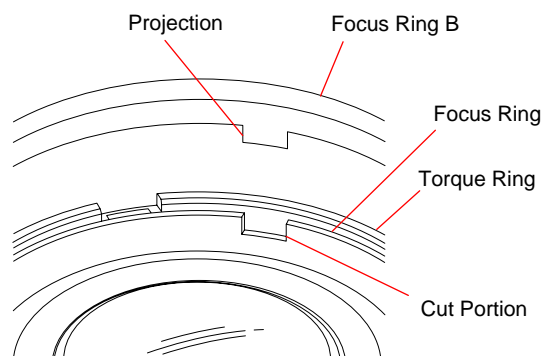
HELP23

Grease (G-115): J-6082-627-A

1. Apply the grease (G-115) to the indicated portion (entire circumference) of focus ring B.



2. Insert the focus ring B, aligning its projection with the cut portion of focus ring.

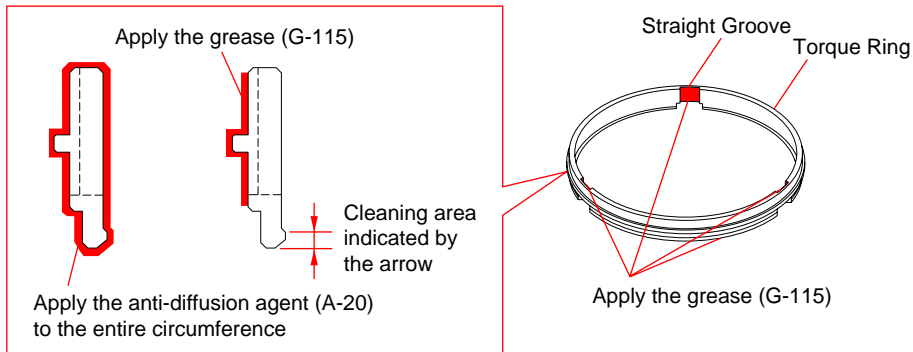


HELP24

Anti-diffusion agent (A-20): J-6082-611-A

Grease (G-115): J-6082-627-A

1. Apply the anti-diffusion agent (A-20) to the indicated portion of torque ring.
2. Apply the grease (G-115) to the indicated portion (entire circumference) and straight key of torque ring.
3. After applying the grease (G-115) and anti-diffusion agent (A-20), clean the area indicated by the arrow.

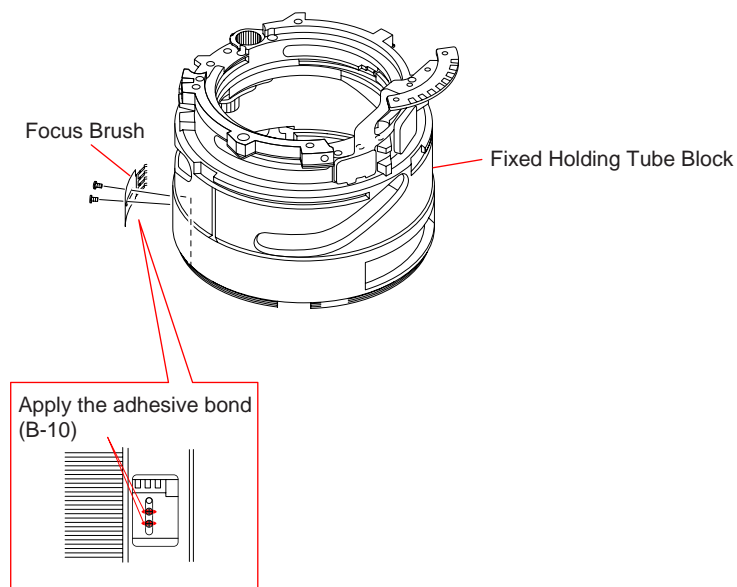


HELP25

Adhesive bond (B-10): J-6082-612-A

After adjusting the focus brush, tighten two screws to fix the focus brush, and apply the adhesive bond (B-10) to the indicated portion.

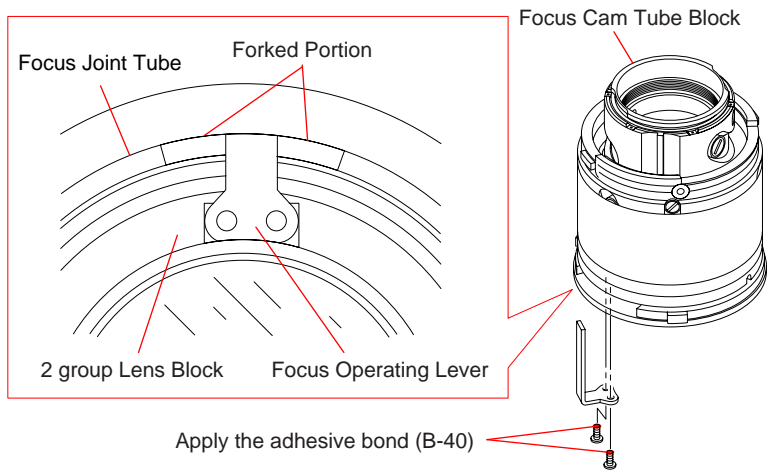
Note: For focus brush adjustment, refer to P.4-38.



HELP26

Adhesive bond (B-40): J-6082-614-A

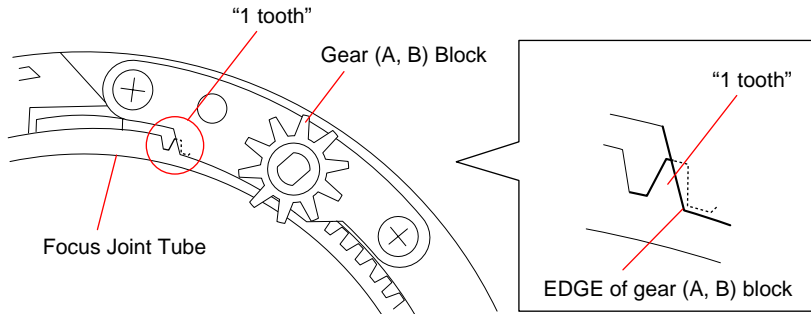
1. Set the zoom to “Tele end”. Insert the focus operating lever in the forked portion of focus joint tube and attach it to the 2nd lens block.
2. Apply the adhesive bond to the tips of two screws and tighten them as shown in figure.



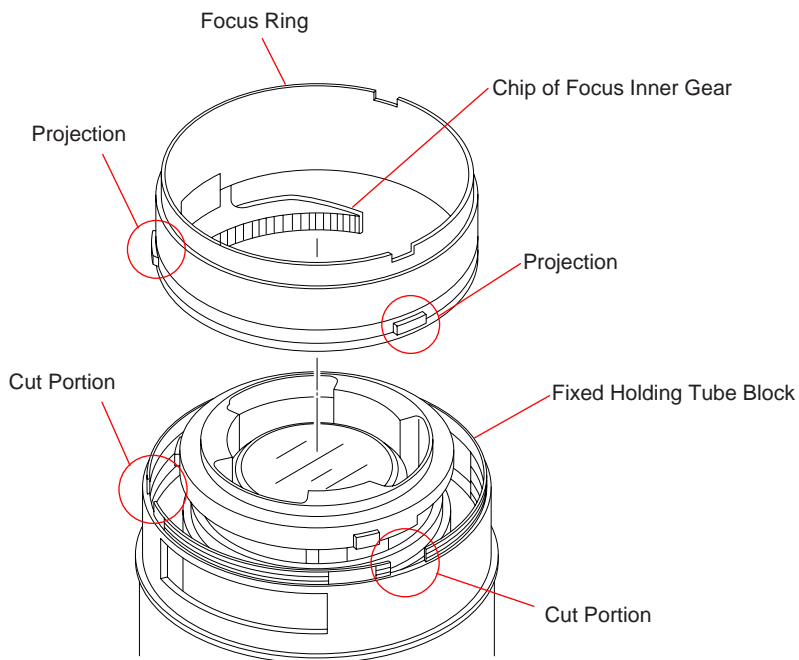
HELP27

Adhesive bond (B-10): J-6082-612-A

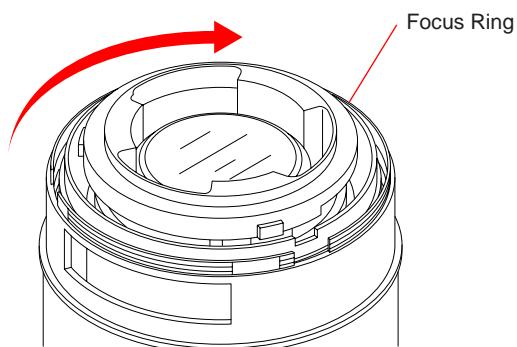
1. Rotate the focus joint tube so that "half of 1 tooth" can be hide out from the support of gear (A, B) block.



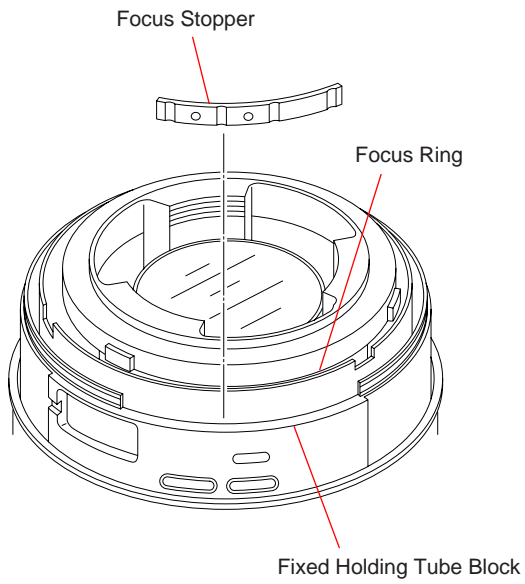
2. Insert the focus ring, aligning its projection (The chip of focus inner gear should locate at the gear (A, B) block) with the cut portion of fixed holding tube block



3. Rotate clockwise the focus ring so that distance tube gear engages with the gear block (A, B) lock.



4. Insert the focus stopper in the gap between the fixed holding tube block and the focus ring as shown in the figure.



5. After focus-shift adjustment, apply the adhesive bond (B-10) to the two screws of focus stopper.
Note: Perform focus-shift adjustment, refer to 4-25 page.

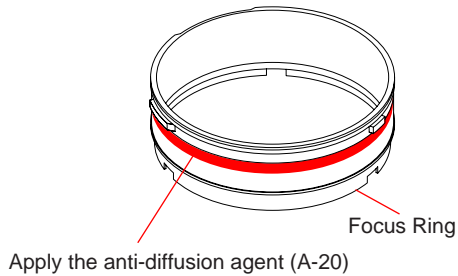
HELP28

Anti-diffusion agent (A-20): J-6082-611-A

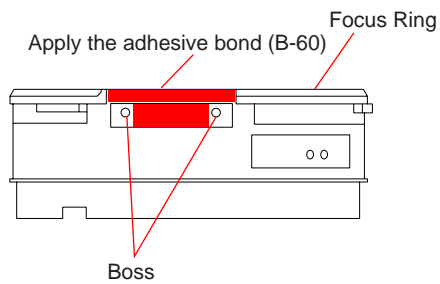
Adhesive bond (B-60): J-6082-616-A

Grease (G-85): J-6082-626-A

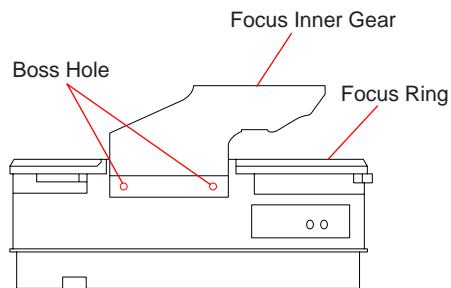
1. Apply the anti-diffusion agent (A-20) to the indicated portion (entire circumference) shown in the figure.



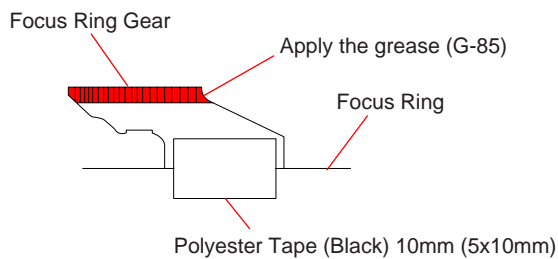
2. Apply the adhesive bond (B-60) to the position of focus ring shown in the figure.



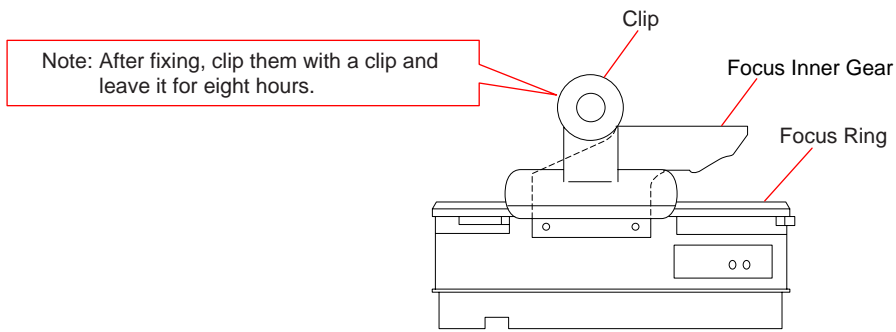
3. Affix the focus inner gear, aligning its boss hole with the boss of focus ring.



4. Affix the polyester tape (black) 10mm of size shown in the figure to the position shown in the figure.
Apply the grease (G-85) to the indicated portion shown in the figure.



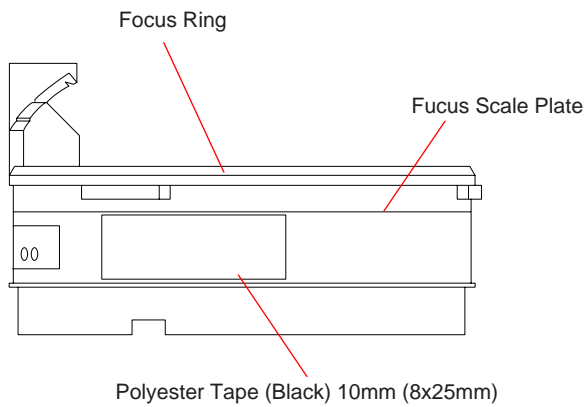
5. Fix the focus inner gear and the focus ring with the clip.



HELP29

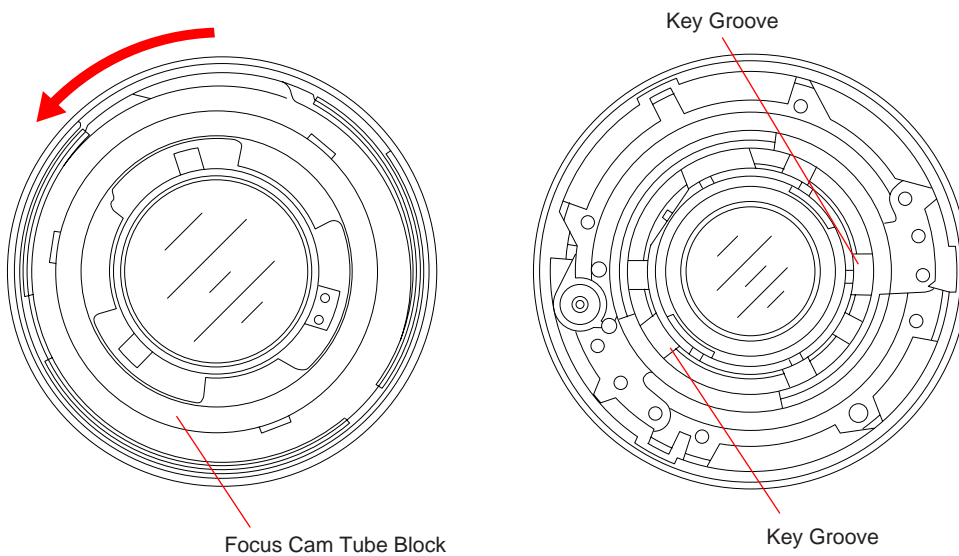
Winding the focus scale tube around the focus ring, affix it with the polyester tape (black) 10mm.

Note: To adjust the focus scale plate position, make the focus scale plate to rotate.



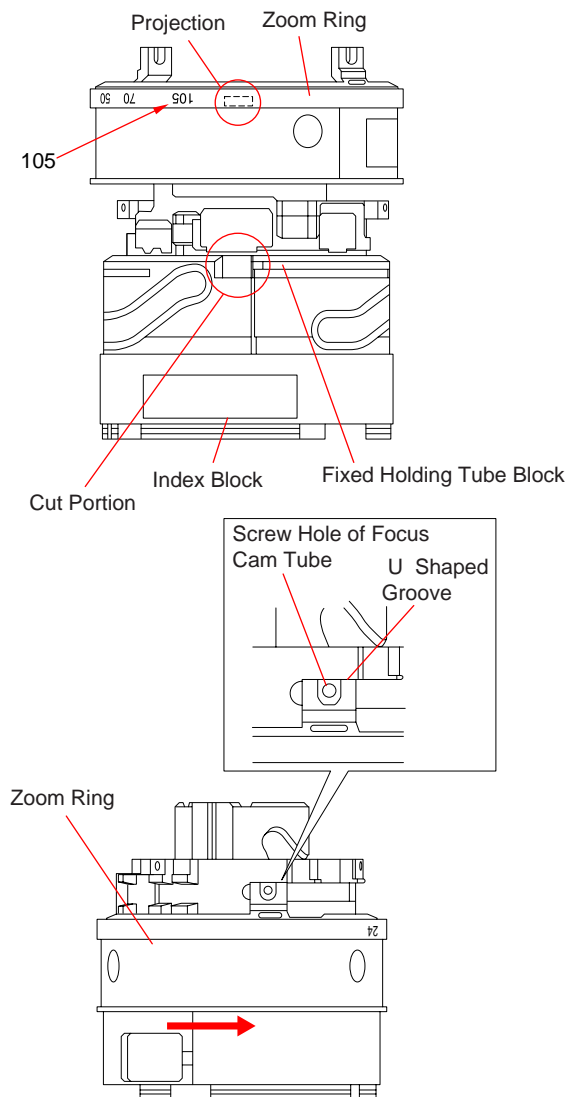
HELP30

1. Set the focus cam tube block to the Wide end by rotating it counterclockwise, and set the zoom ring to the Wide end.
2. Insert the linear guide key A and linear guide key B in the key groove of focus cam tube block.



HELP31

1. Attach the zoom ring, aligning its projection (near “105”) with the cut portion (cut portion of index block) of fixed holding tube block.
2. Rotate counterclockwise the zoom ring a little and tighten the zoom operating pin, aligning the “U” shaped groove with the screw hole of focus cam tube.

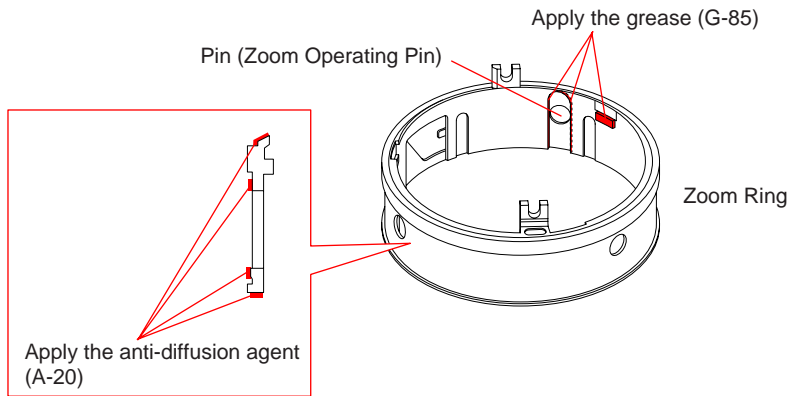


HELP32

Grease (G-85): J-6082-626-A

Anti-diffusion agent (A-20): J-6082-611-A

1. Apply the anti-diffusion agent (A-20) to the indicated portion shown in the figure.
2. Apply the grease (G-85) to the indicated portion (side of lead groove of indicated inner portion) of zoom ring.

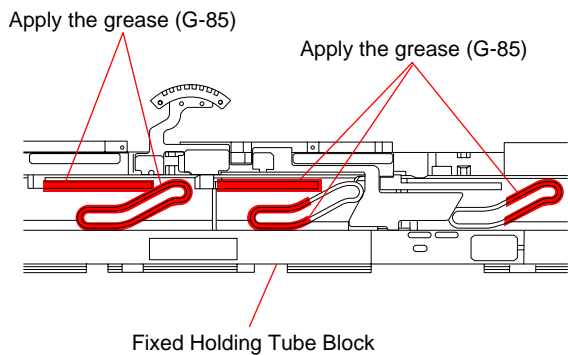


HELP33

Grease (G-85): J-6082-626-A

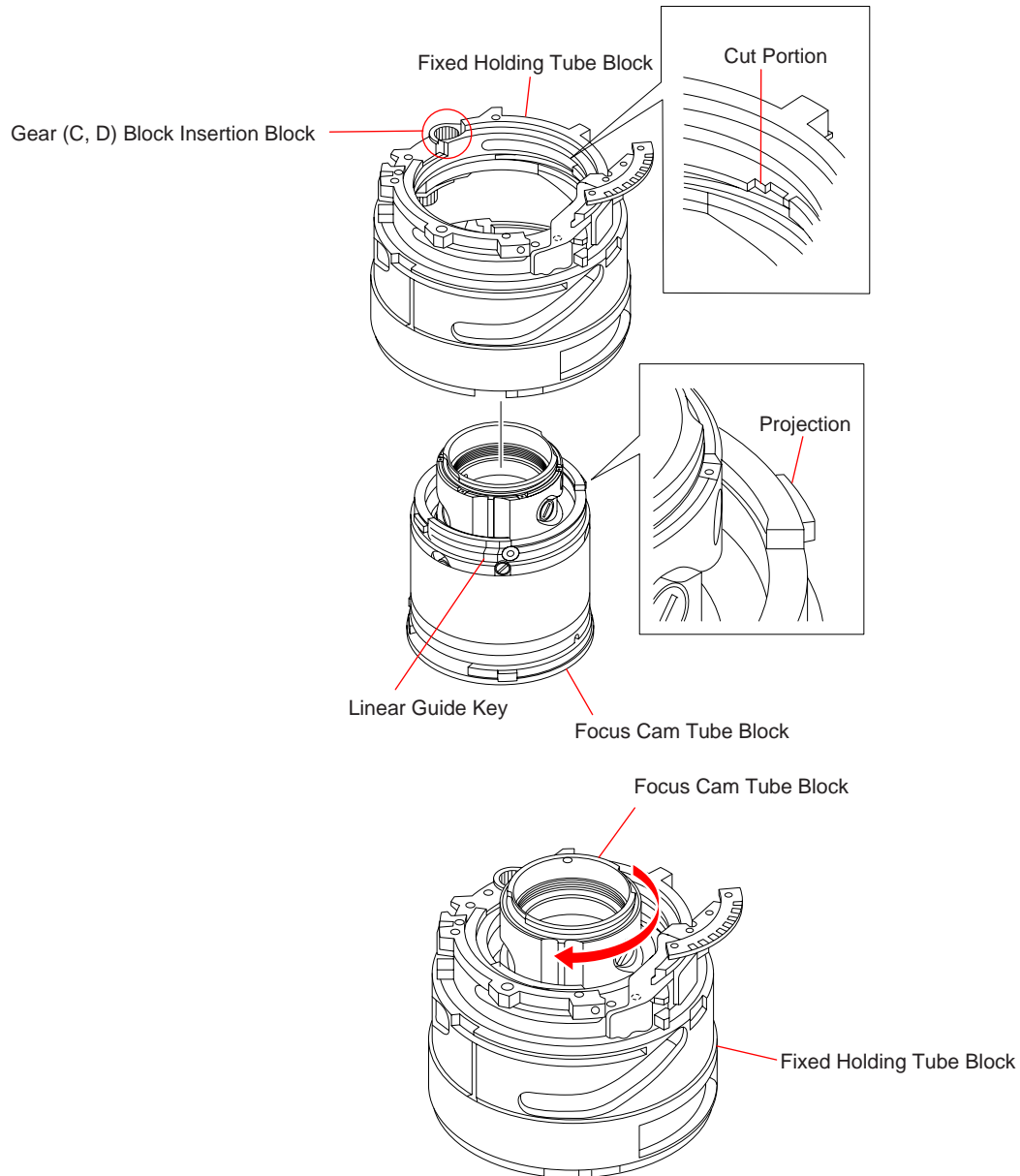
Apply the grease (G-85) to the indicated portion of fixed holding tube block.

Note: Do not apply the grease to the 1/2 area of cam groove near the main flexible PC board block and the slider groove of zoom ring at the lower side of main flexible PC board block.



HELP34

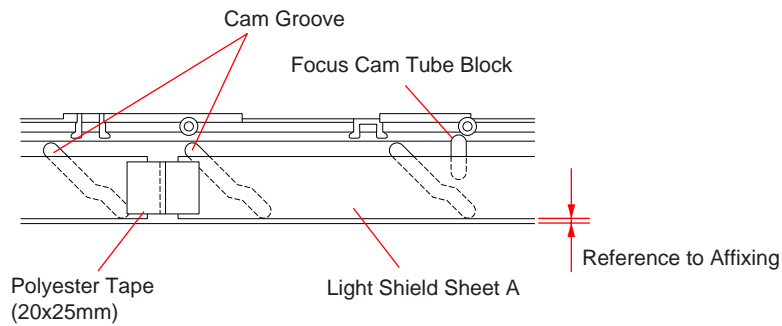
1. Attach the focus cam tube, aligning its projection (the projection furthest to the linear guide key) with the cut portion (cut portion nearest to the gear (C, D) block insertion area) of fixed holding tube block.
2. After installation, rotate the focus cam tube block in the arrow direction.



HELP35

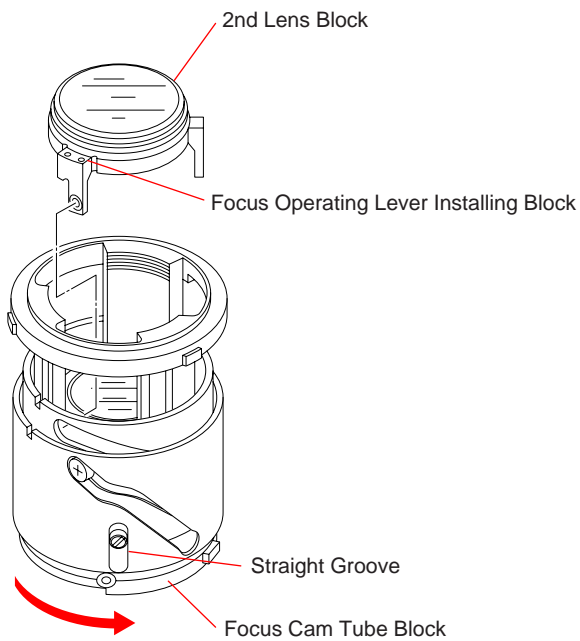
Affix the light shield sheet A with the polyester tape (black) 10mm in the length of 25mm with two sheets overlaid, starting with the position opposite to the straight groove of focus cam tube block.

Note: At this moment, be careful for the polyester tape (black) 10m not to cover by the cam tube.



HELP36

1. Set the focus cam tube block to "Tele end" by rotating the cam tube in the arrow direction.
2. Insert the focus operating lever installing block in the focus cam tube block, aligning.

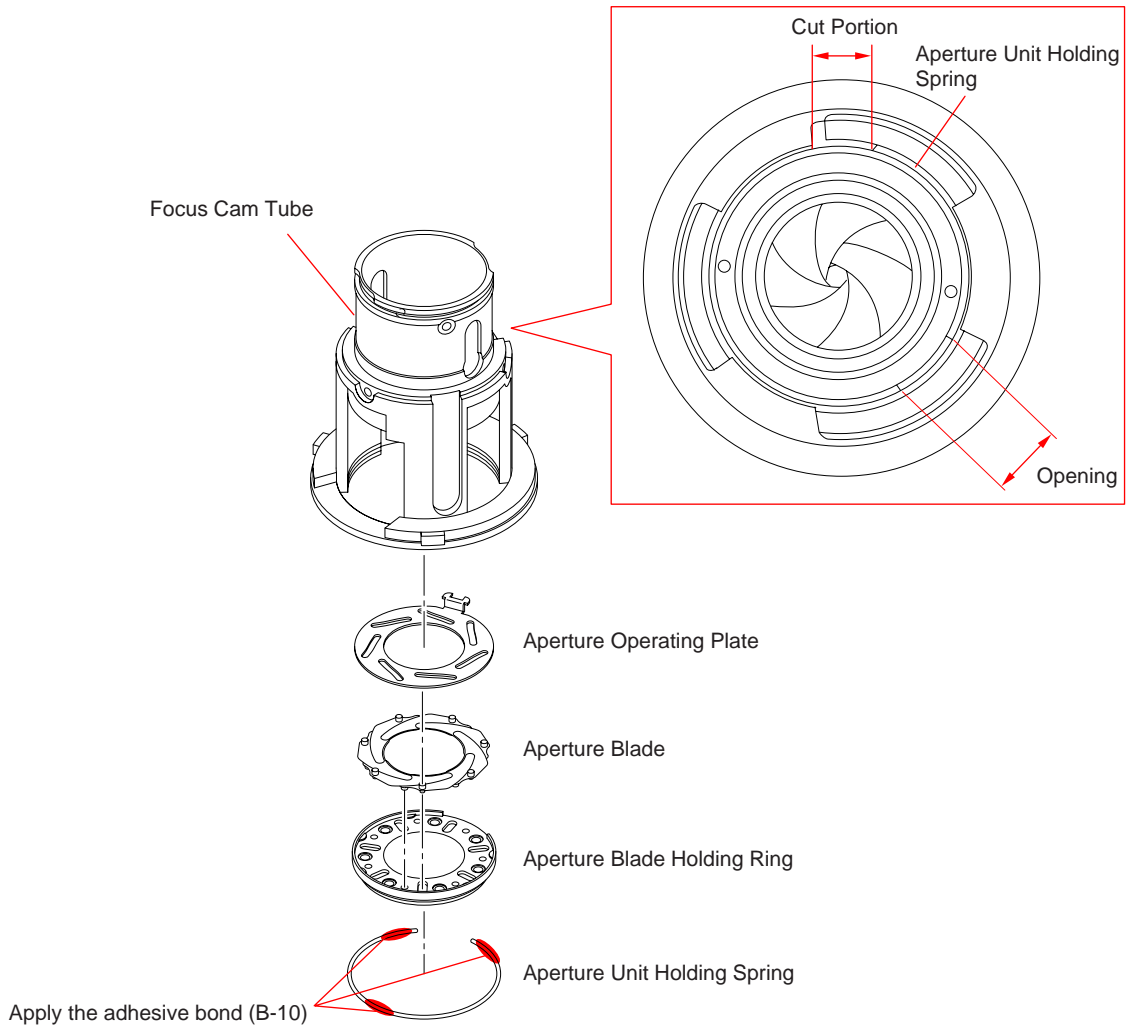


HELP37

Adhesive bond (B-10): J-6082-612-A

1. Attach the aperture unit holding spring so that the opening of aperture unit holding spring does not cover the cut portion of focus cam tube block as shown in the figure.
2. Attach the aperture unit holding spring to the focus cam tube. After adjusting the aperture diameter, apply the adhesive bond (B-10) to the indicated portion.

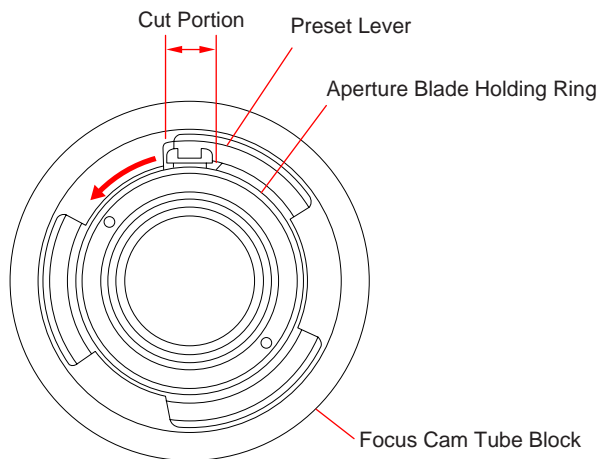
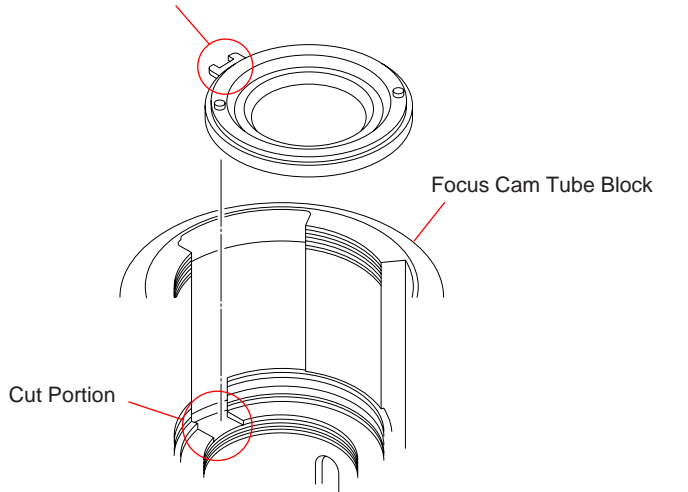
Note: Perform aperture diameter adjustment, referring to 4-16 page.



HELP38

1. Insert the preset lever of aperture operating plate in the focus cam tube block, aligning it with the cut portion of focus cam tube block.
2. Rotate the aperture blade holding ring in the arrow direction so that it disappears from the cut portion of focus cam tube block (state of iris close) as shown in the figure.

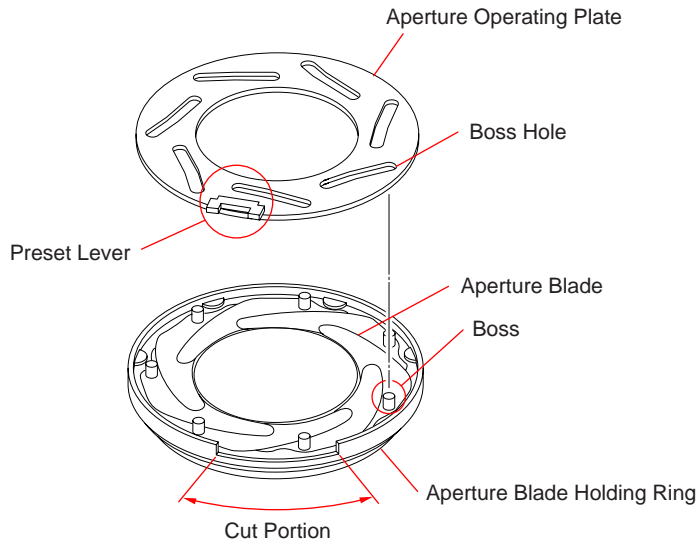
Preset Lever of Aperture Operating Plate



HELP39

Attach the aperture blade, aligning the boss of aperture blade with the boss hole of aperture operating plate.

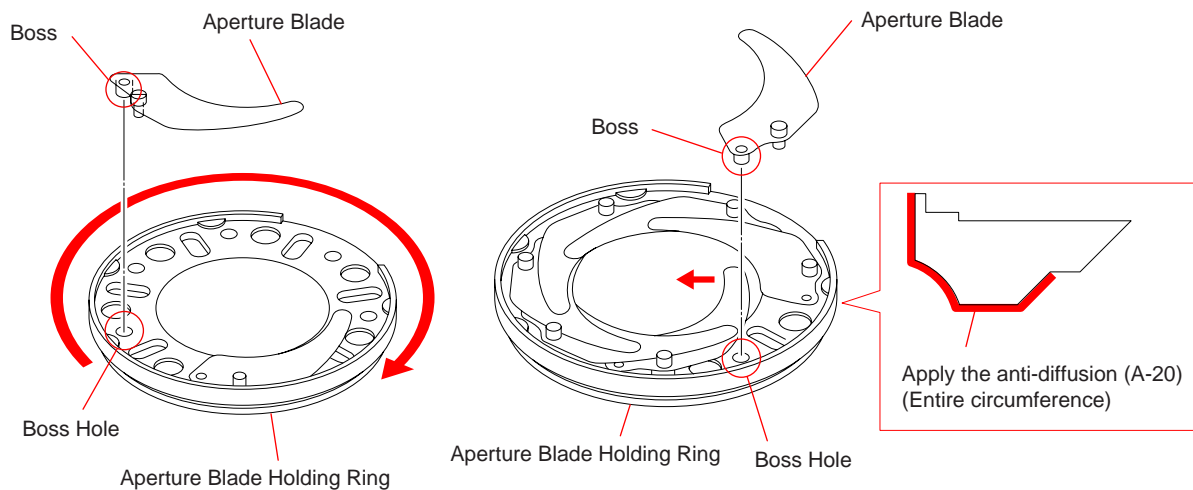
Note: At this moment, the preset lever of aperture operating plate should be in the cut portion of aperture blade holding ring.



HELP40

Anti-diffusion agent (A-20): J-6082-611-A

1. Apply the anti-diffusion (A-20) to the indicated portion of aperture blade holding ring.
2. Attach the aperture blade, aligning its boss with the boss hole of aperture blade holding ring. At this moment, overlay the aperture blade clockwise.
3. Attach the last aperture blade, releasing the blade installed first in the arrow direction.

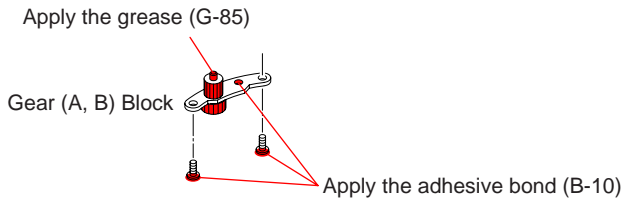


HELP41

Grease (G-85): J-6082-626-A

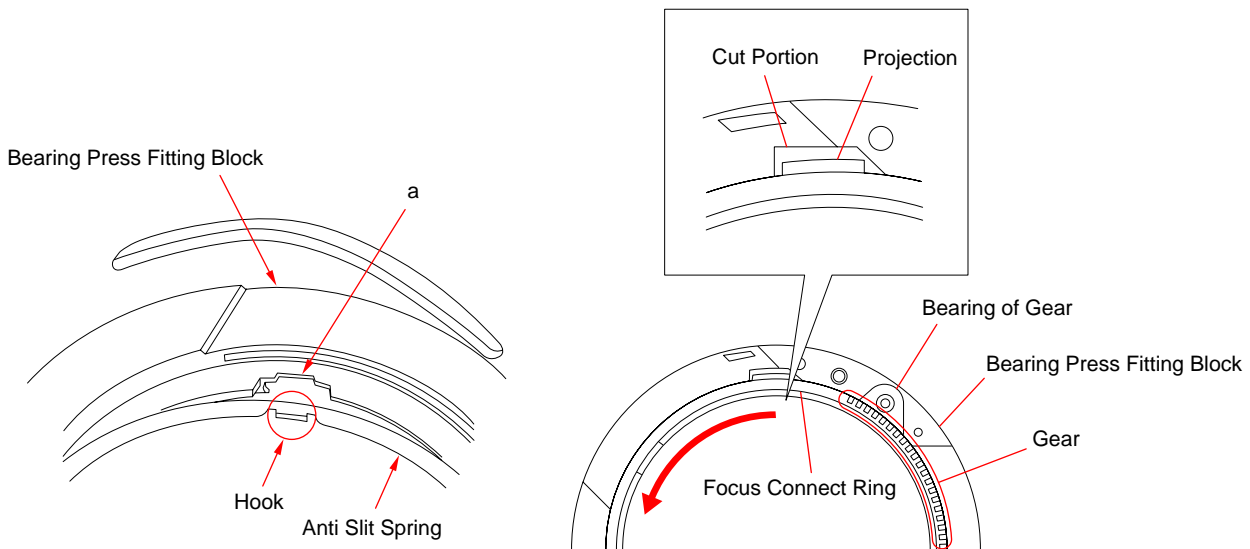
Adhesive bond (B-10): J-6082-612-A

1. Apply the grease (G-85) to the portion indicated in the figure.
2. Apply the adhesive bond (B-10) to the indicated portions shown in the figure of tips of two screws and gear (A, B) block.



HELP42

1. Attach the hook of anti slit spring to the cut portion "a" of bearing press fitting block.
Note: When operation load is heavy, remove the anti slit spring.
2. Attach the projection of focus connect ring in the cut portion of bearing press fitting block at three locations as shown in the figure so that the gear of focus connect ring comes to the bearing of gear of bearing press fitting block. Then, rotate it in the arrow direction.



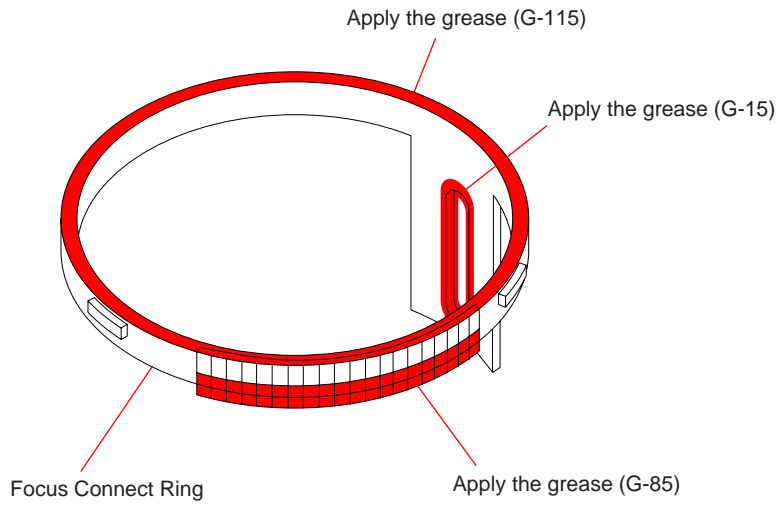
HELP43

Grease (G-15): J-682-619-A

Grease (G-85): J-682-626-A

Grease (G-115): J-682-627-A

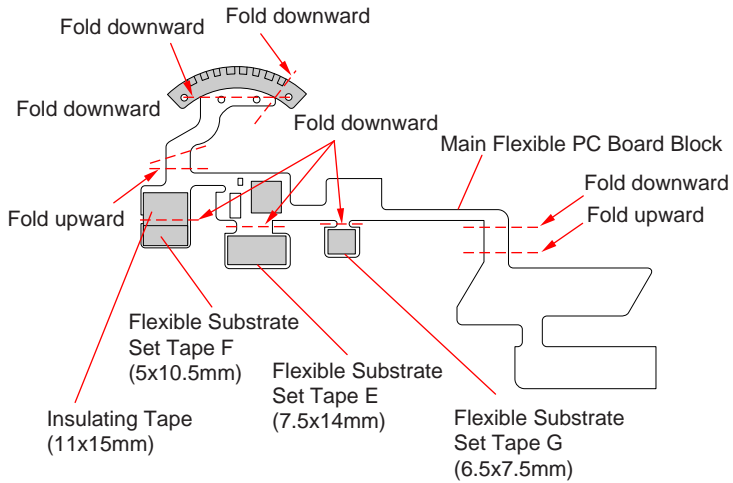
Apply the grease (G-15), grease (G-85) and grease (115) to the indicated portions of focus connect ring.



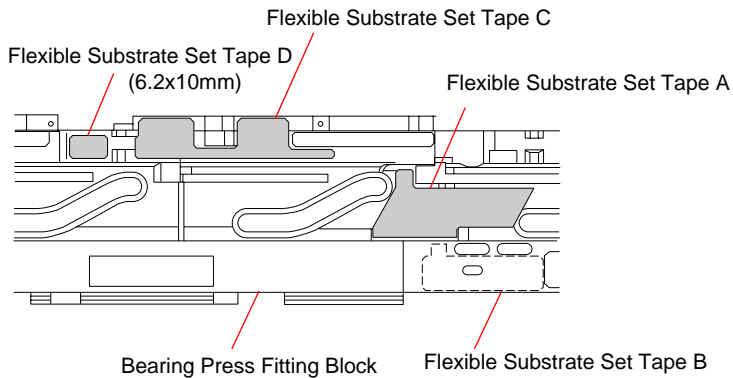
HELP44

Adhesive bond (B-10): J-6082-612-A

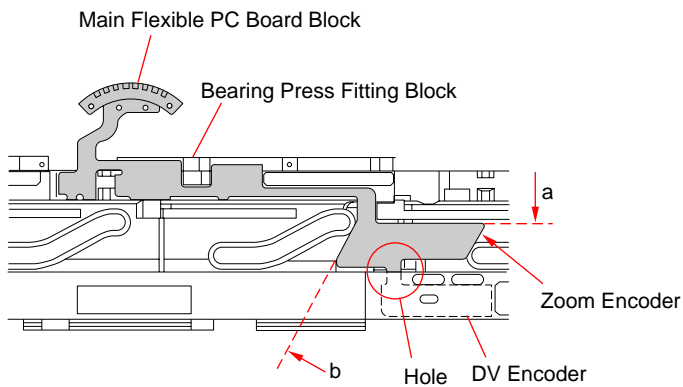
1. Affix the flexible substrate set tape and insulating tape to the locations shown in the figure of main frame flexible PC board block.
2. Fold the main frame flexible board block as instructed.



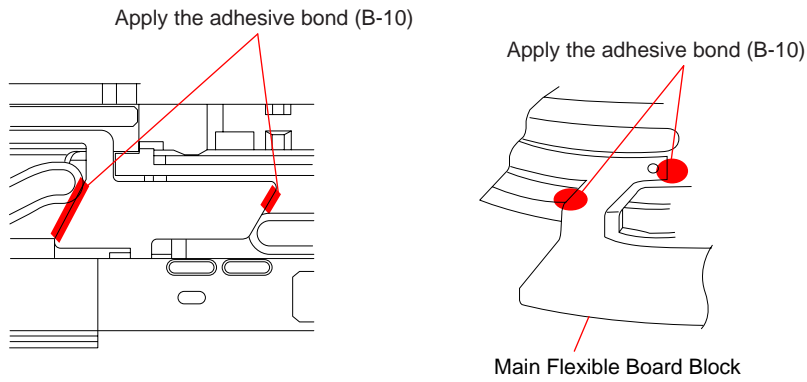
3. Affix the flexible substrate set tape A, flexible substrate set tape B, flexible substrate set tape C and flexible substrate set tape D to the locations shown in the figure of bearing press fitting block.



4. Affix the main flexible PC board block to the bearing press fitting block, threading the DV encoder block of main flexible PC board block in the hole of bearing press fitting block. When affixing, use "a" and "b" as references. Affix the DV encoder block in parallel with the edge surface of bearing press fitting block.



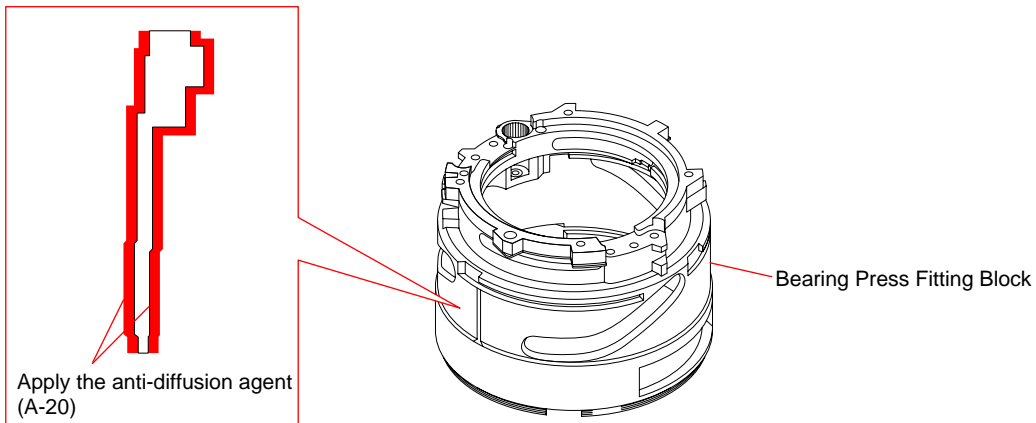
- Apply the adhesive bond (B-10) to the portions indicated in the figure.



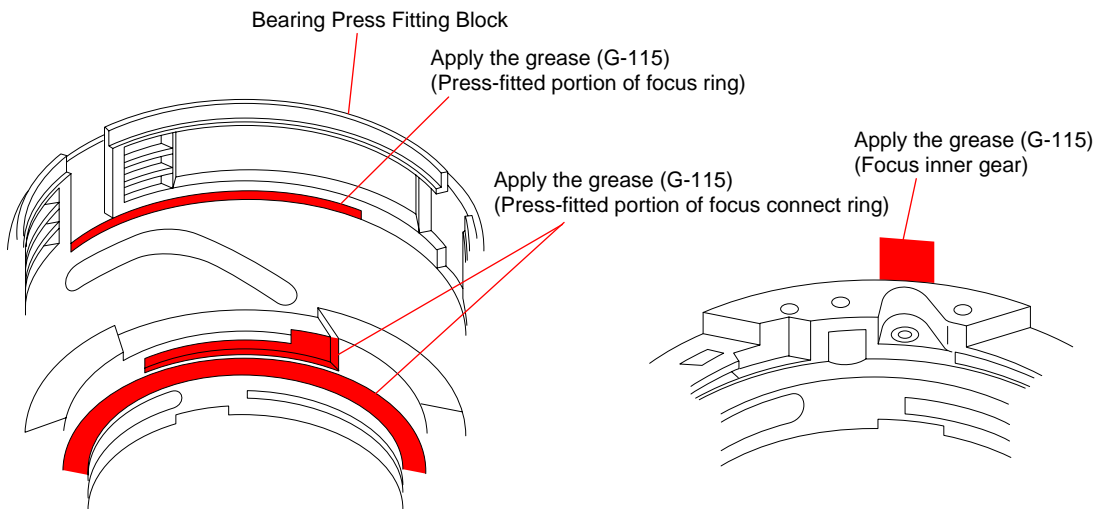
HELP45

Grease (G-115): J-6082-627-A
 Anti-diffusion agent (A-20): J-6082-611-A

- Apply the anti-diffusion agent (A-20) to the indicated portion of bearing press fitting block.



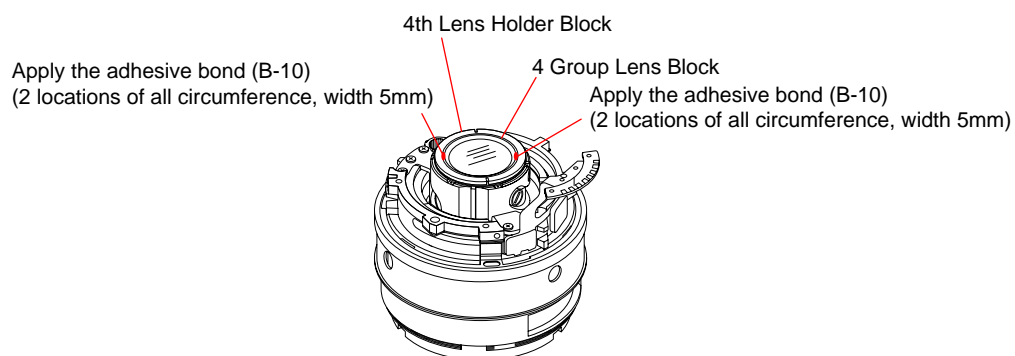
- Apply the grease (G-115) to the indicated portion of bearing press fitting block.



HELP46

Adhesive bond (B-10): J-6082-612-A

1. Install the 4 group lens block to the focus cam tube block.
2. Tighten the 4th lens hold washer shown in figure.
3. Apply the adhesive bond (B-10) to the 2 locations of all circumference of 4 group lens block and 4th lens hold washer.



3. REPAIR PARTS LIST

DISASSEMBLY

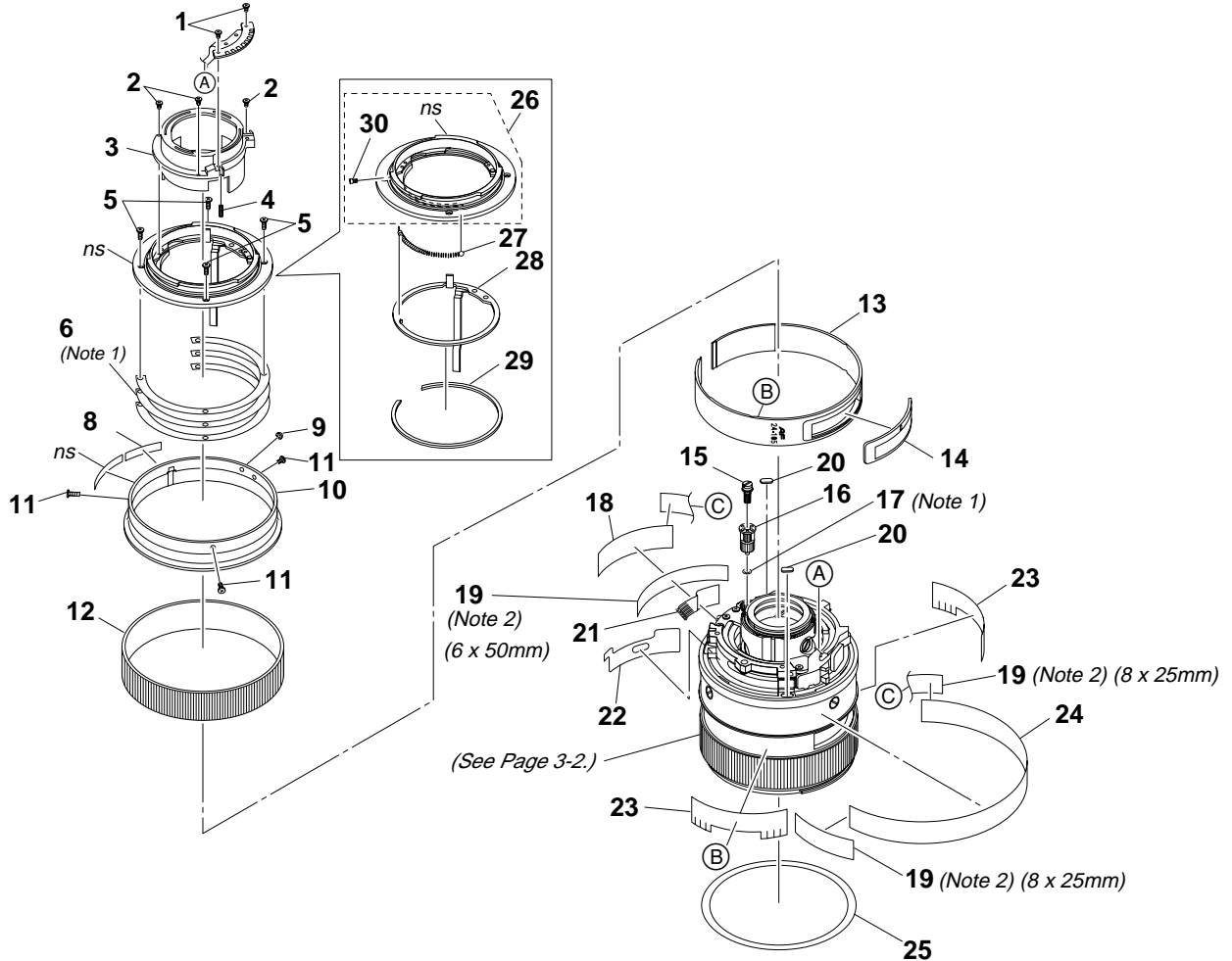
NOTE:

- -XX and -X mean standardized parts, so they may have some difference from the original one.
- Items marked “*” are not stocked since they are seldom required for routine service. Some delay should be anticipated when ordering these items.
- The mechanical parts with no reference number in the exploded views are not supplied.

3-1. EXPLODED VIEWS

3-1-1. LENS MOUNT BLOCK AND OUTER COVER

ns: not supplied



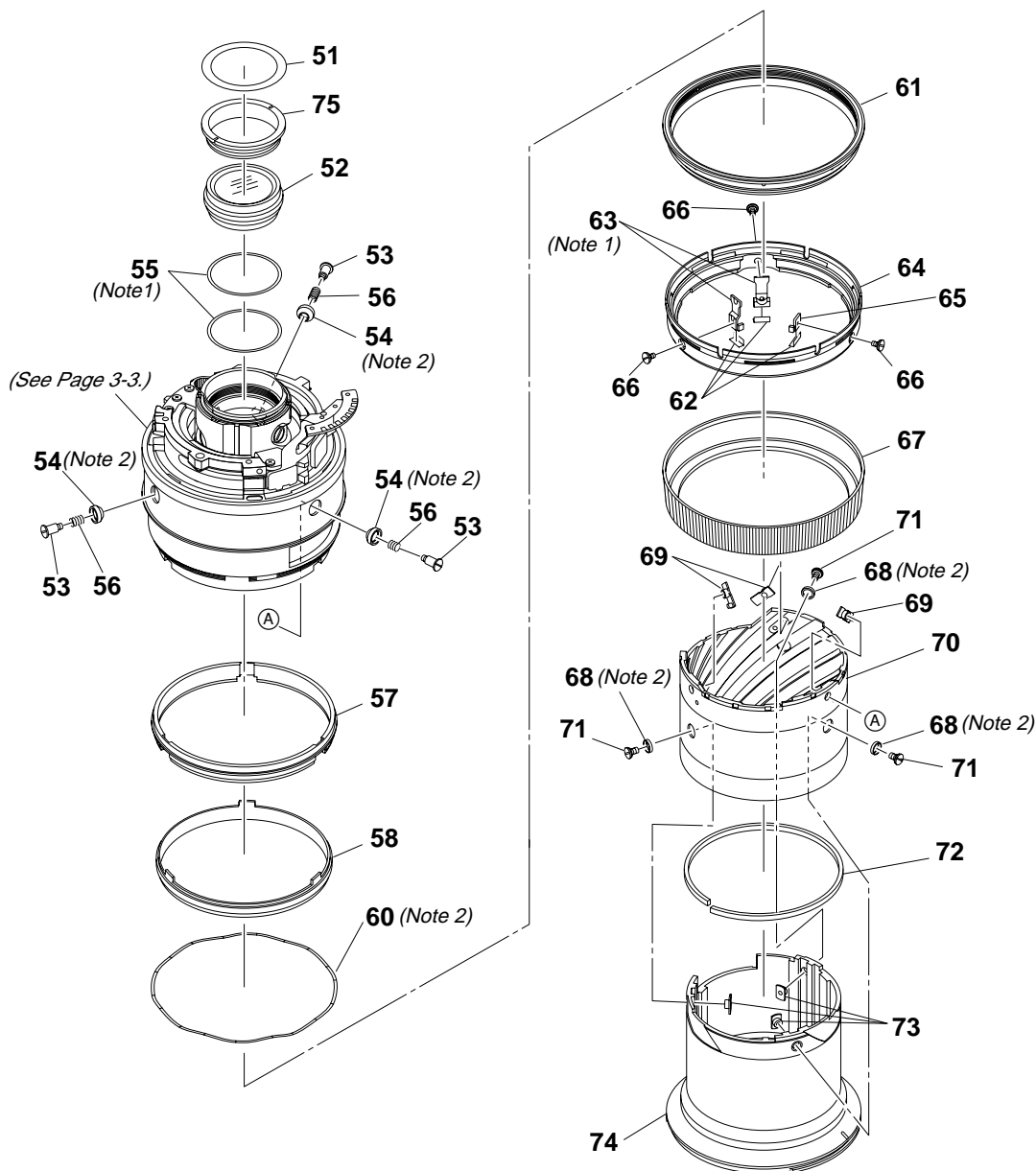
(Note 1) The number or type of these parts need to be selected according to adjustment etc..
Select the part referring to page 3-6.

(Note 2) Cut the polyester tape (black) 10mm (per roll) (Ref. No. 19) for specified size.

Ref. No.	Part No.	Description
1	2-684-066-01	SCREW, TAPPING P1 M1.7X4.0
2	2-684-064-01	SCREW, M1.4X2.2 P1
3	2-688-153-01	REAR LIGHT SHIELD BARREL
4	2-684-065-01	GROUND SPRING
5	2-698-464-01	SCREW, TAPPING M2.0X5.5
6	Selection parts	BACK ADJUSTMENT WASHER (A to E) (Note 1)
8	2-695-847-01	LABEL, MODEL NAME
9	2-683-692-01	CHIP (MOUNT INDEX)
10	2-688-364-01	RING(ZOOM HOLD RING)
11	2-887-124-01	SCREW, TAPPING M1.7X4.0
12	2-688-399-01	RUBBER (ZOOM RUBBER RING)
13	2-688-400-01	COVER (OUTER COVER)
14	A-1207-253-A	UNIT(FOCUS SCALE WINDOW UNIT)
15	2-688-248-01	SHAFT (AF COUPLER)

Ref. No.	Part No.	Description
16	A-1207-246-A	BLOCK, GEAR (C,D)
17	Selection parts	COUPLER ADJUSTMENT WASHER (A to E) (Note 1)
18	2-688-209-01	BRUSH COVER
19	9-913-210-03	POLYESTER TAPE (BLACK) 10mm (Note 2)
20	2-688-271-01	RUBBER (TORQUE ADJUSTMENT)
21	2-688-222-01	CONTACT CHIP (ZOOM BRUSH)
22	2-688-303-01	DECORATION COVER SET TAPE
23	2-688-304-01	DECORATION COVER SET TAPE B
24	2-688-208-01	ZOOM RING REINFORCEMENT PLATE
25	2-688-366-01	PLATE (DECORATION PLATE)
26	A-1207-248-A	BLOCK, MAIN SP GUIDE RIVETING
27	2-688-406-01	MAIN SPRING
28	A-1194-992-A	PRESET RING GUIDE ASSY
29	2-684-234-01	PRESET RING HOLDING PLATE
30	2-684-244-01	STOPPER SCREW

3-1-2. FIRST MOVING FRAME AND 1ST LENS BARREL HOLDER



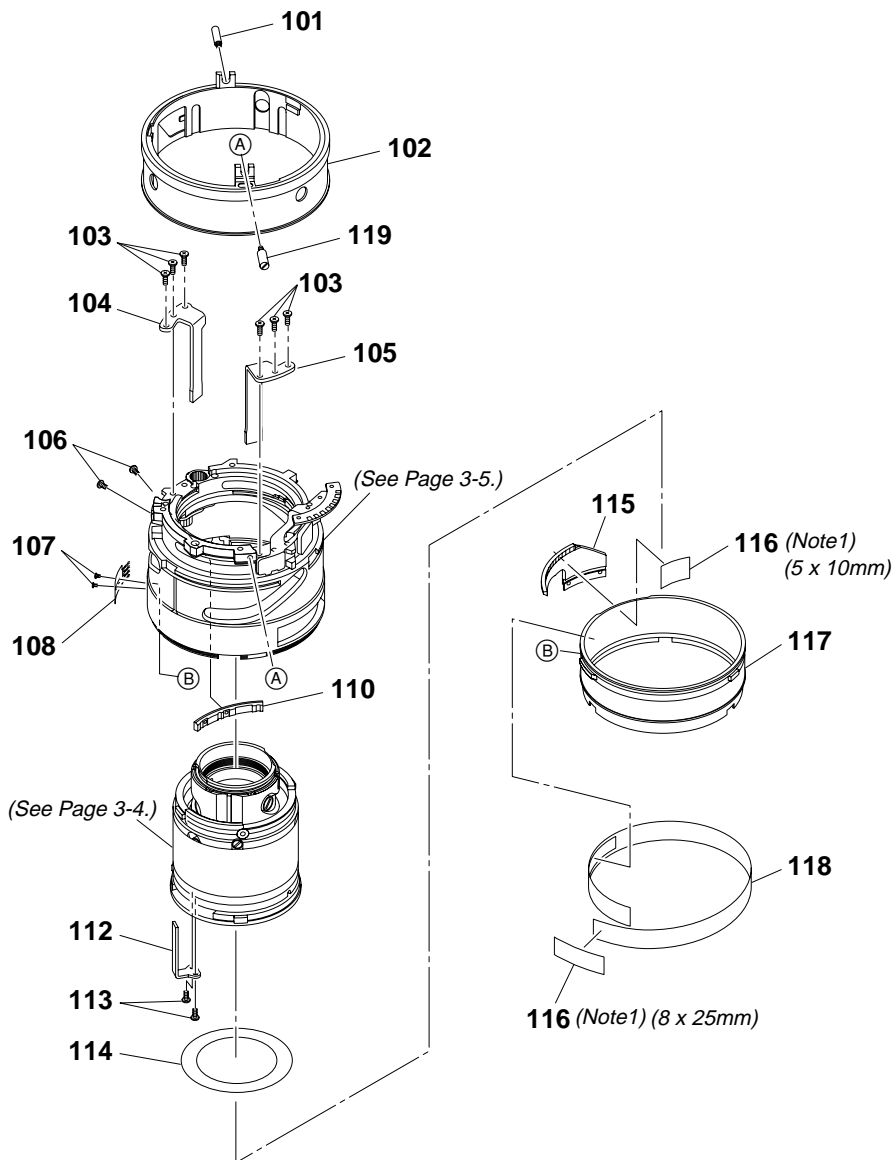
(Note 1) The number or type of these parts need to be selected according to adjustment etc..
Select the part referring to page 3-6.

(Note 2) Select the type of part according to the operation load of the associated parts.
Select the part referring to page 3-6.

Ref. No.	Part No.	Description
51	2-688-207-01	LIGHT SHIELD PLATE B
52	A-1207-251-A	BLOCK, 4 GROUP LENS
53	2-688-278-01	PIN(1ST MOVING FRAME GUIDE PIN)
54	Selection parts	1ST MOVING FRAME GUIDE ROLLER (A to C) (Note 2)
55	Selection parts	G3-4 ADJUSTMENT WASHER (A to E) (Note 1)
56	2-688-282-01	1ST MOVING FRAME GUIDE SPRING
57	2-688-154-01	RING (TORQUE RING)
58	2-688-155-01	RING (FOCUS RING B)
60	Selection parts	SPRING (TORQUE RING SPRING (A to C)) (Note 2)
61	2-688-363-01	RING (TORQUE HOLD RING)
62	2-688-311-01	SHEET (SCRATCH PREVENION)
63	Selection parts	PINCH LEVER (or C) (Note 1)

Ref. No.	Part No.	Description
64	2-688-151-01	MF OPERATION RING
65	2-688-257-01	LEVER (PINCH LEVER B)
66	2-688-256-01	PIN (PINCH LEVER SHAFT)
67	2-688-398-01	FOCUS RUBBER RING
68	Selection parts	1ST LENS BARREL GUIDE ROLLER (A to D) (Note 2)
69	2-688-347-01	NUT B
70	2-688-149-01	FIRST MOVING FRAME
71	2-688-273-01	PIN(1ST LENS BARREL GUIDE PIN)
72	2-688-272-01	FRICTION SHEET
73	2-688-345-01	SCREW (NUT)
74	A-1207-250-A	BLOCK, 1 GROUP LENS
75	2-898-685-01	4TH LENS HOLD WASHER

3-1-3. FOCUS CAM TUBE BLOCK, ZOOM RING AND FOCUS RING



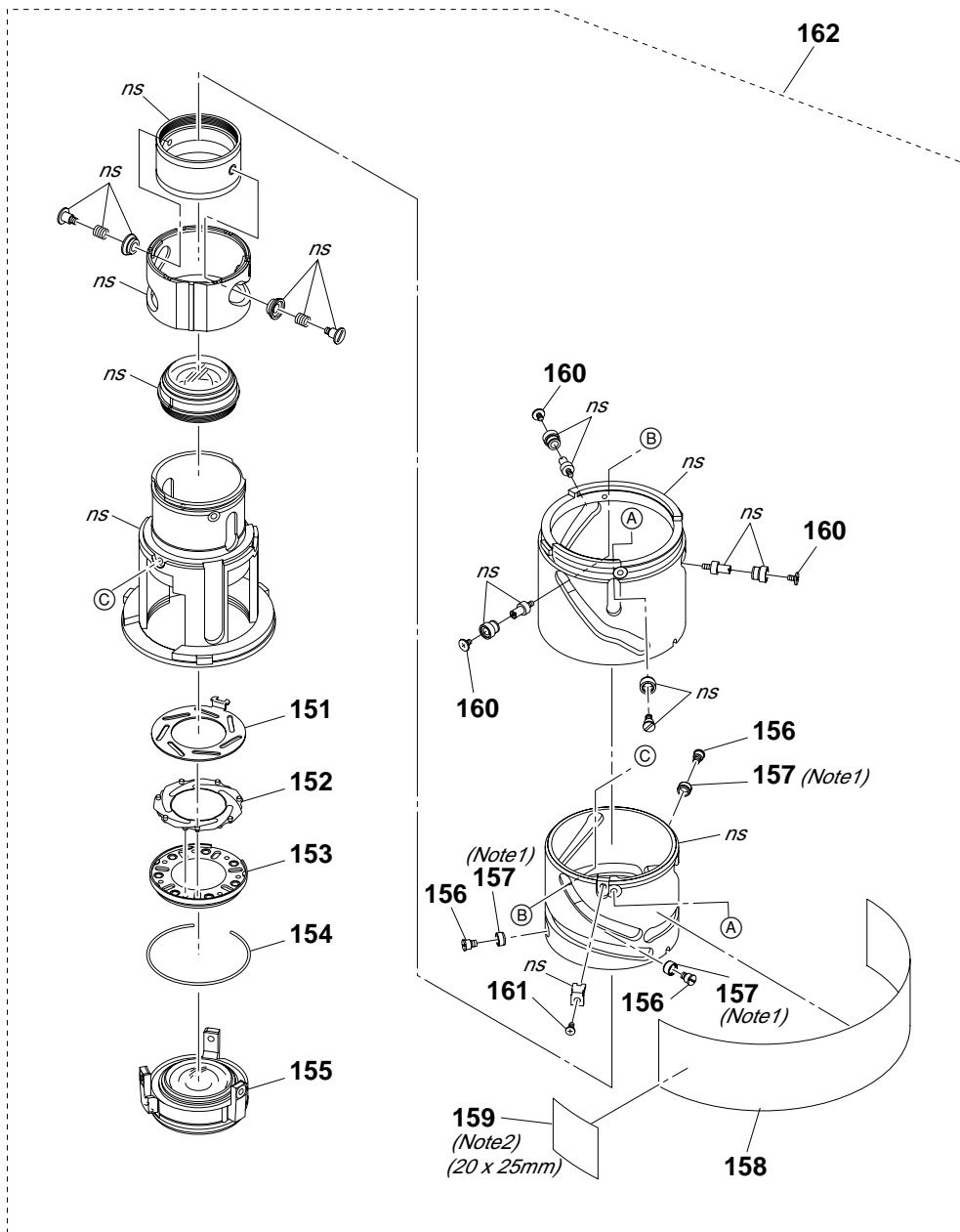
(Note 1) Cut the polyester tape (black) 10mm (per roll) (Ref. No. 116) for specified size.

Ref. No.	Part No.	Description
101	2-688-270-01	PIN (ZOOM OPERATING PIN)
102	2-688-362-01	RING(ZOOM RING)
103	2-698-498-01	SCREW, TAPPING M1.7X5.0
104	2-688-213-01	LEVER (LINEAR GUIDE KEY B)
105	2-688-212-01	LEVER (LINEAR GUIDE KEY A)
106	2-684-762-01	PHI3 HEAD SCREW M1.6X2.5
107	2-887-123-01	SCREW, M1.4X1.6 P1
108	2-688-221-01	FOCUS BRUSH
110	2-688-259-01	FOCUS STOPPER

Ref. No.	Part No.	Description
112	2-688-246-01	FOCUS OPERATING LEVER
113	2-685-694-01	SCREW, M1.6X4.0
114	2-688-206-01	LIGHT SHIELD PLATE A
115	2-688-205-01	GEAR(FOCUS INNER GEAR)
116	9-913-210-03	POLYESTER TAPE (BLACK) 10mm (Note 1)
117	2-688-150-01	RING(FOCUS RING)
118	2-688-396-01	PLATE (FOCUS SCALE PLATE)
119	3-218-506-01	ZOOM, OPERATING, PIN B

3-1-4. APERTURE BLADE BLOCK AND 2 GROUP LENS BLOCK

ns: not supplied



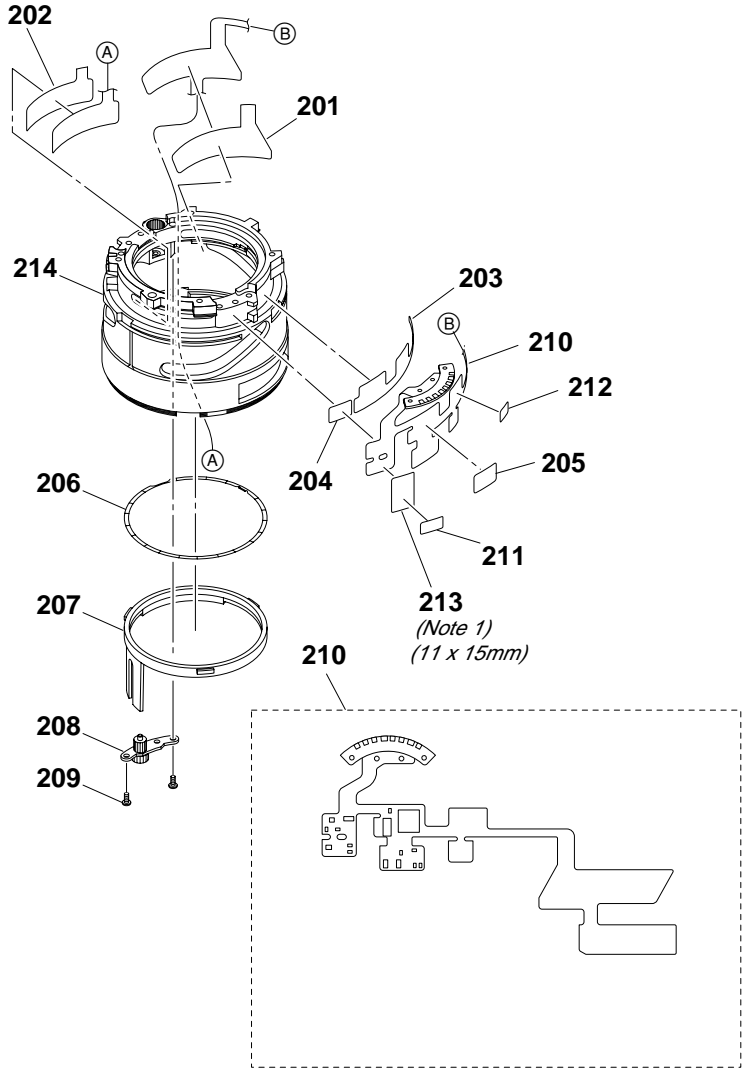
(Note 1) Select the type of part according to the operation load of the associated parts.
Select the part referring to page 3-6.

(Note 2) Affix the polyester tape (black) 10mm (per roll) (Ref. No. 159) in the length of 25mm with two sheet overlaid.

Ref. No.	Part No.	Description
151	2-688-144-01	PLATE(APERTURE OPERATING PLATE)
152	2-688-416-01	APERTURE BLADE
153	2-688-411-01	RING(APERTURE BLADE HOLDING)
154	2-688-410-01	APERTURE UNIT HOLDING SPRING
155	A-1207-241-A	BLOCK, 2 GROUP LENS
156	2-688-260-01	PIN(2ND MOVING FRAME GUIDE PIN)

Ref. No.	Part No.	Description
157	Selection parts	2ND MOVING FRAME GUIDE ROLLER (A to F) (Note 1)
158	2-688-308-01	LIGHT SHIELD SHEET A
159	9-913-210-03	POLYESTER TAPE (BLACK) 10mm (Note 2)
160	2-685-585-01	PHI4 HEAD SCREW M1.6X2.5
161	2-684-762-01	PHI3 HEAD SCREW M1.6X2.5
162	A-1207-237-A	BLOCK, FOCUS CAM TUBE

3-1-5. MAIN FLEXIBLE PC BOARD BLOCK AND FOCUS CONNECT RING



(Note 1) Cut the insulating tape (per roll) (Ref. No. 213) for specified size.

Ref. No.	Part No.	Description
201	2-688-312-01	TAPE(FLEXIBLE SUBSTRATE SET A)
202	2-688-313-01	FLEXIBLE SUBSTRATE SET TAPE B
203	2-688-314-01	TAPE(FLEXIBLE SUBSTRATE SET C)
204	2-688-315-01	FLEXIBLE SUBSTRATE SET TAPE D
205	2-688-316-01	FLEXIBLE SUBSTRATE SET TAPE E
206	2-688-211-01	ANTI SLIP SPRING
207	2-688-152-01	FOCUS CONNECT RING

Ref. No.	Part No.	Description
208	A-1207-244-A	BLOCK, GEAR (A,B)
209	2-887-125-01	SCREW, TAPPING M1.7X4.5
210	A-1202-191-A	BLOCK, MAIN FLEXIBLE PC BOARD
211	2-688-317-01	SHEET(FLEXIBLE SUBSTRATE SET F)
212	2-688-326-01	FLEXIBLE SUBSTRATE SET TAPE G
* 213	9-913-210-01	INSULATING TAPE (Note 1)
214	A-1207-243-A	BLOCK,(BEARING) PRESS FITTING

3-1-6. SELECTION PARTS**Ref. No.6**

These washers are provided for flange back adjustment.
Change the thickness (t) according to result of adjustment.

<u>Part No.</u>	<u>Description</u>
2-688-527-01	BACK ADJUSTMENT WASHER (A) (t=0.05mm)
2-688-528-01	BACK ADJUSTMENT WASHER (B) (t=0.07mm)
2-688-529-01	BACK ADJUSTMENT WASHER (C) (t=0.1mm)
2-688-530-01	BACK ADJUSTMENT WASHER (D) (t=0.2mm)
2-688-531-01	BACK ADJUSTMENT WASHER (E) (t=0.5mm)

Ref. No.17

These washers are provided for coupler height adjustment.
Change the thickness (t) according to result of adjustment.

<u>Part No.</u>	<u>Description</u>
2-684-057-01	COUPLER ADJUSTMENT WASHER (A) (t=0.05mm)
2-684-058-01	COUPLER ADJUSTMENT WASHER (B) (t=0.07mm)
2-684-059-01	COUPLER ADJUSTMENT WASHER (C) (t=0.1mm)
2-684-060-01	COUPLER ADJUSTMENT WASHER (D) (t=0.2mm)
2-684-061-01	COUPLER ADJUSTMENT WASHER (E) (t=0.5mm)

Ref. No.54

Select the type of part according to the operation load of the associated parts.

<u>Part No.</u>	<u>Description</u>
2-688-279-01	1ST MOVING FRAME GUIDE ROLLER A (D=6.03mm)
2-688-280-01	1ST MOVING FRAME GUIDE ROLLER B (D=6.02mm)
2-688-281-01	1ST MOVING FRAME GUIDE ROLLER C (D=6.01mm)

Ref. No.55

These washers are provided for projective resolving power check (warp).
Change the thickness (t) according to result of adjustment.

<u>Part No.</u>	<u>Description</u>
2-688-215-01	G3-4 ADJUSTMENT WASHER A (t=0.05mm)
2-688-216-01	G3-4 ADJUSTMENT WASHER B (t=0.07mm)
2-688-217-01	G3-4 ADJUSTMENT WASHER C (t=0.1mm)
2-688-218-01	G3-4 ADJUSTMENT WASHER D (t=0.2mm)
2-688-219-01	G3-4 ADJUSTMENT WASHER E (t=0.3mm)

Ref. No.60

Select the type of part according to the operation load of the associated parts.

<u>Part No.</u>	<u>Description</u>
2-688-243-01	SPRING (TORQUE RING SPRING A)
2-688-244-01	SPRING (TORQUE RING SPRING B)

Ref. No.63

Use the pinch lever usually, replace the pinch lever C when focus clutch mechanism runs idle. In case use pinch lever C, replace with two it.

<u>Part No.</u>	<u>Description</u>
2-688-255-01	PINCH LEVER
2-688-258-01	LEVER (PINCH LEVER C)

Ref. No.68

Select the type of part according to the operation load of the associated parts.

<u>Part No.</u>	<u>Description</u>
2-688-274-01	1ST LENS BARREL GUIDE ROLLER A (D=4.32mm)
2-688-275-01	1ST LENS BARREL GUIDE ROLLER B (D=4.31mm)
2-688-276-01	1ST LENS BARREL GUIDE ROLLER C (D=4.30mm)
2-688-277-01	1ST LENS BARREL GUIDE ROLLER D (D=4.29mm)
2-688-277-11	1ST LENS BARREL GUIDE ROLLER D (D=4.28mm)
2-688-277-21	1ST LENS BARREL GUIDE ROLLER D (D=4.27mm)

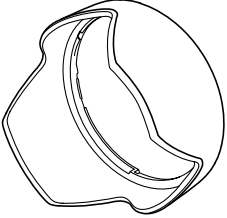
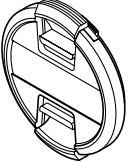
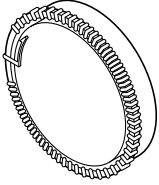
Ref. No.157

Select the type of part according to the operation load of the associated parts.

<u>Part No.</u>	<u>Description</u>
2-688-266-01	2ND MOVING FRAME GUIDE ROLLER A (D=4.23mm)
2-688-267-01	2ND MOVING FRAME GUIDE ROLLER B (D=4.22mm)
2-688-268-01	2ND MOVING FRAME GUIDE ROLLER C (D=4.21mm)
2-688-269-01	2ND MOVING FRAME GUIDE ROLLER D (D=4.18mm)
2-688-298-01	ROLLER (2ND MOVING FRAME GUIDE E) (D=4.20mm)
2-688-299-01	ROLLER (2ND MOVING FRAME GUIDE F) (D=4.19mm)

3-2. SUPPLIED ACCESSORIES

Checking supplied accessories.

		Other accessories 2-686-120-01 MANUAL, INSTRUCTION (JAPANESE, ENGLISH, FRENCH, SPANISH, SIMPLIFIED CHINESE) 2-686-120-11 MANUAL, INSTRUCTION (GERMAN, DUTCH, SWEDISH, ITALIAN) (AEP) 2-686-120-21 MANUAL, INSTRUCTION (PORTUGUESE, RUSSIAN, TRADITIONAL CHINESE, KOREAN, ARABIC) (AEP)
Lens Hood (SH0016) 2-687-332-01	Front Lens Cap 2-687-233-01	
		
Rear Lens Cap 2-683-615-01		

4. ADJUSTMENTS

Note: After the service repair, perform the adjustments referring to this section.

4-1. PREPARATIONS

4-1-1. List of Service Tools and Equipments

- Variable Transformer (Output voltage: AC 100 V) (Note 3)
- Camera DSLR-A100
- Compact Flash (CF) Card (For image saving)
- Screen (Art paper)
- Tape Measure
- Plane Mirror (For SLRs)
- Adhesive bond (B-10): J-6082-612-A
- Lens Adjustment Program (ActuatorChecker.exe)
- PC Card Setup File (InstaCal.exe)
- Color Calculator 2

Note: Color Calculator 2 is downloadable from the ESI homepage.


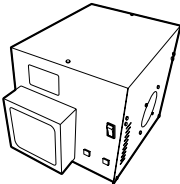

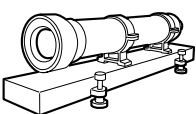
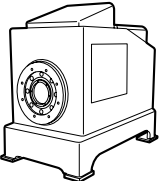
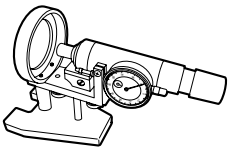
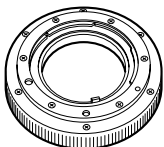
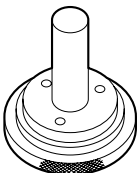
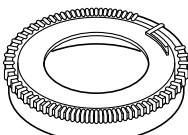
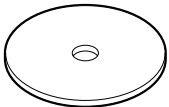
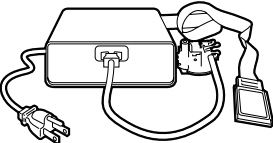
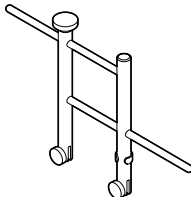
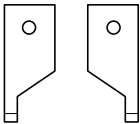
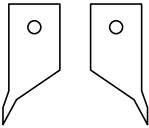
<p>J-1</p>  <p>Personal computer (Note 1)</p>	<p>J-2</p>  <p>Luminance box J-6082-581-A</p>	<p>J-3</p>  <p>AE master lens J-6082-597-A</p>
<p>J-4</p>  <p>1000 mm Collimator 110V: J-6082-604-A 240V: J-6082-604-B (Note 2)</p>	<p>J-5</p>  <p>Lens test projector J-6082-605-A (Note 3)</p>	<p>J-6</p>  <p>Flange back tester J-6082-606-A</p>
<p>J-7</p>  <p>A-mount attachment J-6082-607-A</p>	<p>J-8</p>  <p>Flange back gauge (43.50mm) J-6082-608-A</p>	<p>J-9</p>  <p>Maximum Aperture jig J-6082-640-A</p>
<p>J-10</p>  <p>Aberration measuring cap 62mm (SAL24105) J-6082-646-A</p>	<p>J-11</p>  <p>Finished Inspection JIG J-6082-645-A (Note 4)</p>	<p>J-12</p>  <p>Universal wrench J-6082-609-A</p>
<p>J-13</p>  <p>Chip-A for universal wrench: J-6082-609-1</p>	<p>J-14</p>  <p>Chip-B for universal wrench: J-6082-609-2</p>	

Fig. 4-1-1

Note 1: Personal Computer (PC)
(Color Calculator 2 installed)
OS: Windows XP
MEMORY: 40 M Byte or more recommended
Hard disk free area: 15 M Byte or more recommended
USB terminal: Standard equipment
Graphics: 32,000 colors or more recommended VGA monitor

Note 2: Attach the chart to the 1000 mm collimator as shown in Fig. 4-1-2.

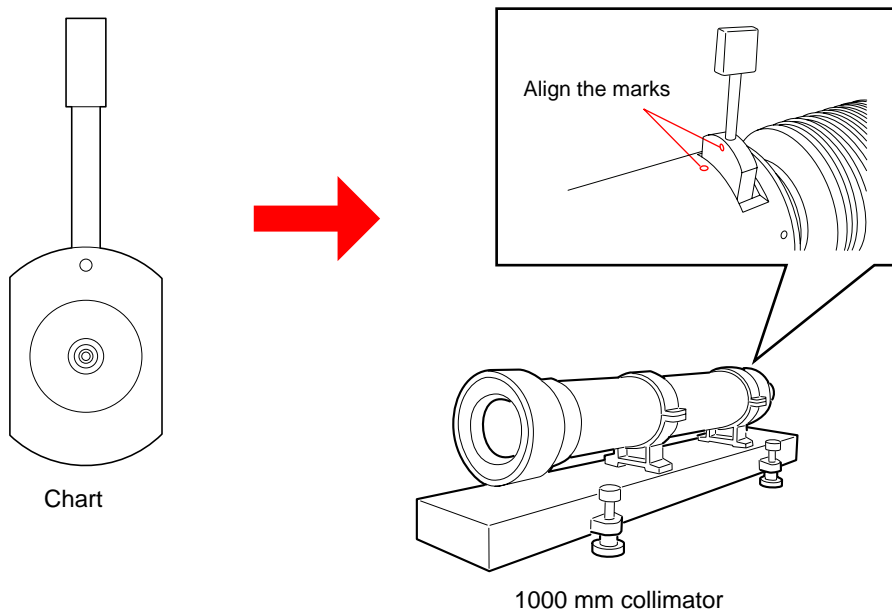


Fig. 4-1-2

Note 3: Connect the variable transformer (Output voltage: **AC 100 V**) to the lens test projector.

Note 4: Finished Inspection JIG is **AC 100 V** only.

4-1-2. Lens Adjustment Program (ActuatorChecker)

The lens adjustment program is required for the following check/adjustment.

4-5. FOCUS-SHIFT CHECK/ADJUSTMENT (APERTURE)

4-8. LENS ROM CHECK

4-9. ZOOM BRUSH POSITION CHECK/ADJUSTMENT

4-10. FOCUS BRUSH POSITION CHECK/ADJUSTMENT AND PATTERN CHECK

Prepare/start the lens adjustment program with the following steps.

Equipment used

- Personal Computer
- Lens Adjustment Program (ActuatorChecker.exe)
- PC Card Setup File (InstaCal.exe)

Note 1: Lap top PC with PC card slot on which Windows XP runs

Note 2: Obtain the PC card setup file (InstaCal.exe) from the ESI homepage.

Note 3: Obtain the lens adjustment program (ActuatorChecker Ver. x.x.x.x.zip) from the ESI homepage.

1. Download of PC card setup file (InstaCal.exe)

- 1) Create the "MCC" folder in the C drive.

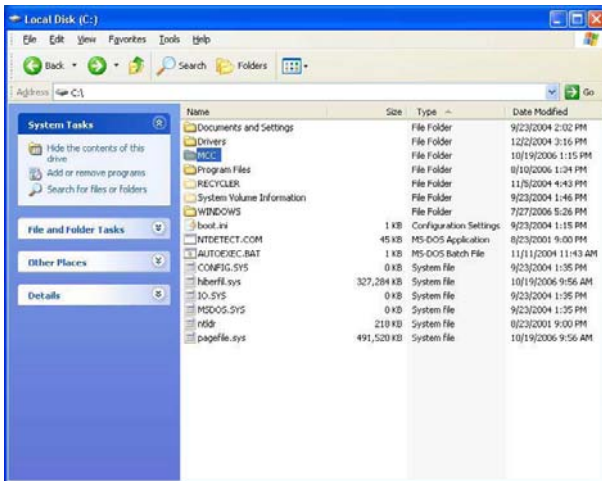


Fig.4-1-3

- 2) Download the file from Service Fixture and Software of ESI homepage, and save it in "C:\MCC".
- 3) Double-click the downloaded file "InstaCal.exe" to extract it.
- 4) The window to specify the extract destination folder appears. Click **Browse...**.

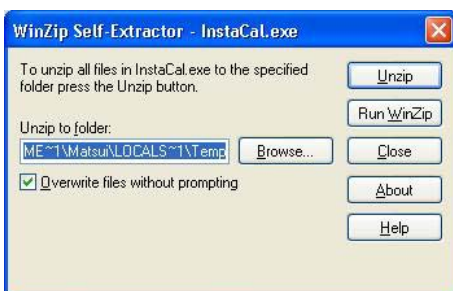


Fig.4-1-4

- 5) Specify “C:\MCC” for the extract destination folder.



Fig.4-1-5

- 6) The window returns to the menu to specify the extract destination folder. Click **Unzip**.



Fig.4-1-6

- 7) When the window below appears, click **OK**.



Fig.4-1-7

- 8) Return to the menu to specify the extract destination folder. Then, click **Close** to close the window.

2. Setup of PC Card

- 1) Double-click “InstaCal.exe” in “C:\MCC” folder to begin the installation.

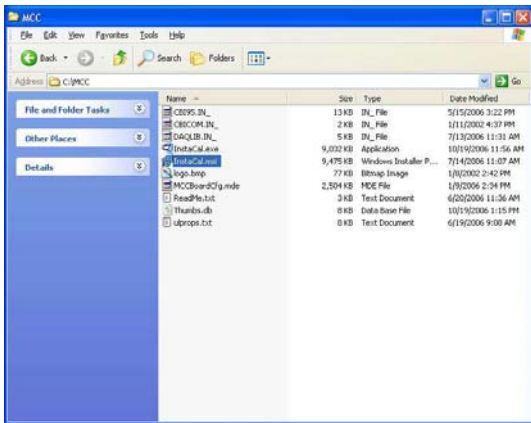


Fig.4-1-8

- 2) The menu to begin the installation appears. Click **Next>**.



Fig.4-1-9

- 3) Specify the install destination folder. As the default is used for it, click **Next>**.



Fig.4-1-10

- 4) The menu to tell that the wizard is ready to install appears. Click **Install**.

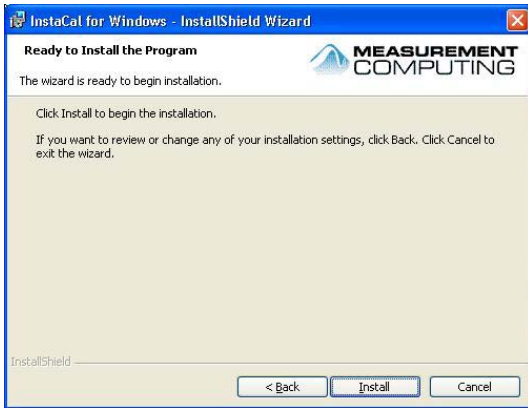


Fig.4-1-11

- 5) The installation is completed. Click **Finish**.

Note: To refer to the “readme” file, check the “Show the readme file” and click **Finish**.



Fig.4-1-12

- 6) To make the configuration installed effective, the window to prompt the restart appears. Click “Yes” to restart the PC.

Note: If a device is connected without restarting, the program may not work properly.

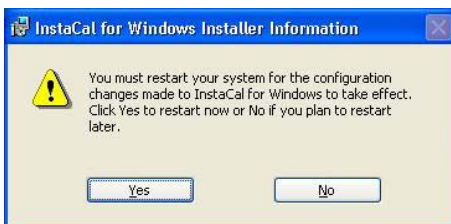


Fig.4-1-13

- 7) After restarting the PC, insert the PC-CARD-DIO48 in the PC card slot.
- 8) The software installation window appears.
Click “Install the software automatically. (Recommended)”.



Fig.4-1-14

- 9) The software is detected and installed. When the window below appears, click **Finish** to terminate the installation.



Fig.4-1-15

3. Confirmation of PC card setting

- 1) Select “All programs” - “MeasurementComputing” - “InstaCal” from the startup menu, and start up the software.

Note: Depending on the Windows setting, the window below may differ.

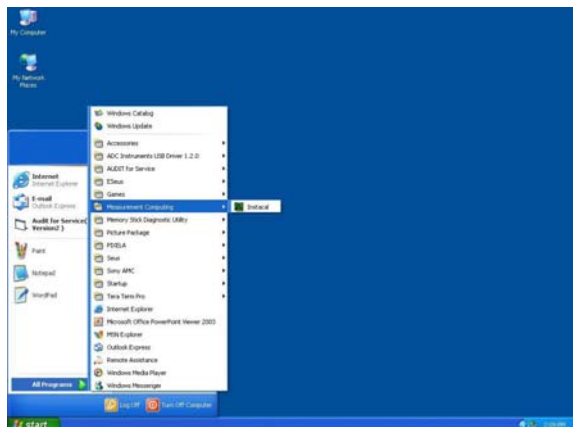


Fig.4-1-16

- 2) When “PC-CARD-DIO48” is detected, the window below appears. Confirm that the PC-CARD-DIO48” is checked.

Note: Depending on the slot inserted, the slot No. differs.



Fig.4-1-17

- 3) Confirm that “PC-CARD-DIO48” is recognized as “Board#0”.

Note: If not recognized as “Board#0”, the program does not work properly.

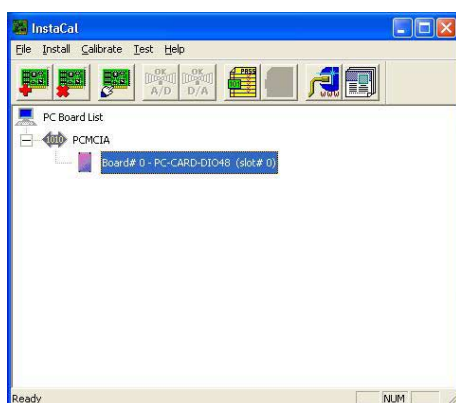


Fig.4-1-18

- 4) Click “File” - “Exit” to terminate “InstaCal”.

4. Startup of Lens Adjustment Program (ActuatorChecker.exe)

- 1) Download the file “ActuatorChecker VerX.X.X.X.zip” from Service Fixture and Software of ESI homepage, save and extract it.
- 2) Start up “ActuatorChecker.exe” from an arbitrary folder.
- 3) If “PC-CARD-DIO48” is properly installed, the window below appears.

Note: The version of “ActuatorCheker” might be updated.

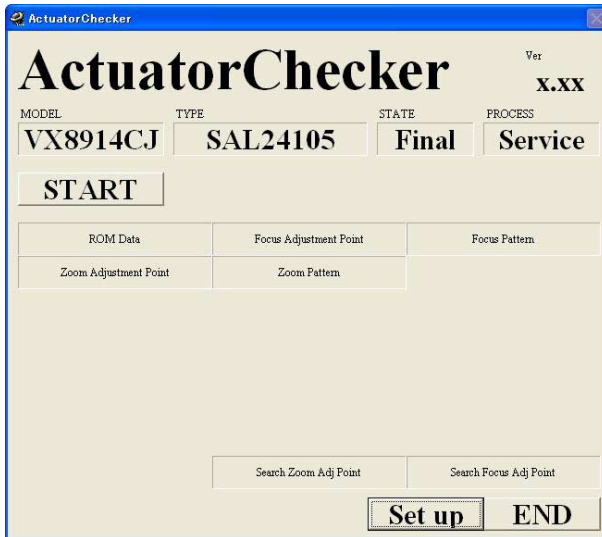


Fig.4-1-19

4-1-3. Connection of Finished Inspection JIG and Lens Adjustment Program (ActuatorChecker.exe)

Note: Confirm “4-1-2. Lens Adjustment Program (ActuatorChecker)” has been completed before this procedure is executed.

Equipment

- Personal Computer
- USB cord with connector
- Finished Inspection JIG (AC100 V only)
- Lens Adjustment Program (ActuatorChecker.exe)

1. Connect equipment and checking lens as shown Fig.4-1-20.

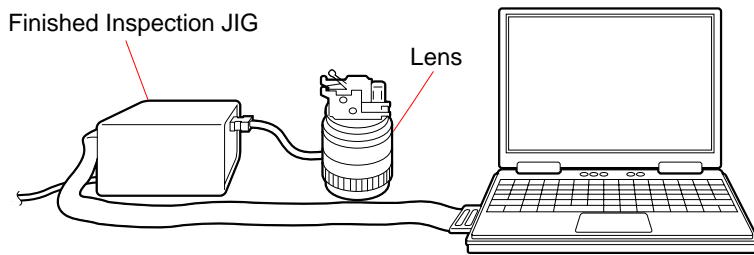


Fig.4-1-20

2. Turn on the finished inspection JIG.
3. Turn on the personal computer.
4. Start up “ActuatorChecker.exe” from an arbitrary folder, conform that start up program normally.

Note: Turn off the finished inspection jig after use.

4-1-4. Initial Setting of “ActuatorChecker”

1. Start up “ActuatorChecker.exe”.

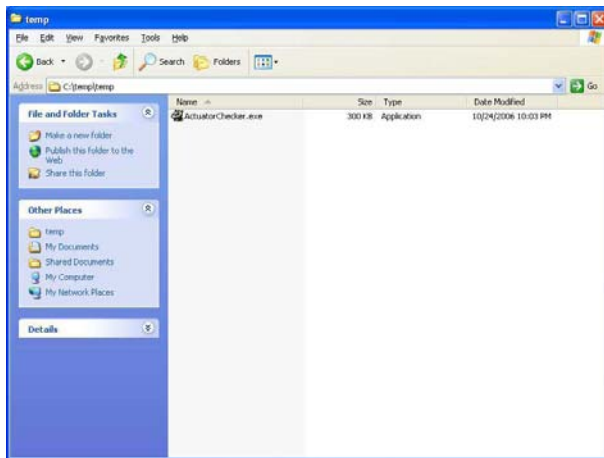


Fig.4-1-21

2. Depending on the initial startup or setting made at the previous startup, the window differs. When the English window appears, click the **Set up** button.

Note: When any button is clicked, the Serial window appears. The window to enter the lens serial number appears.

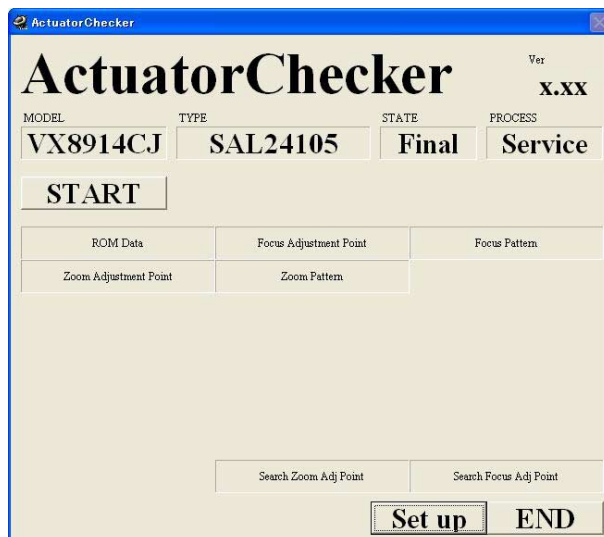


Fig.4-1-22

3. Set the following contents in the SETUP window.
 - MODEL Model to be adjustment this time
 - Language English
 - State FINAL
 - PROCESS SERVICE
4. Confirm that all of the items are set, and click **OK**.

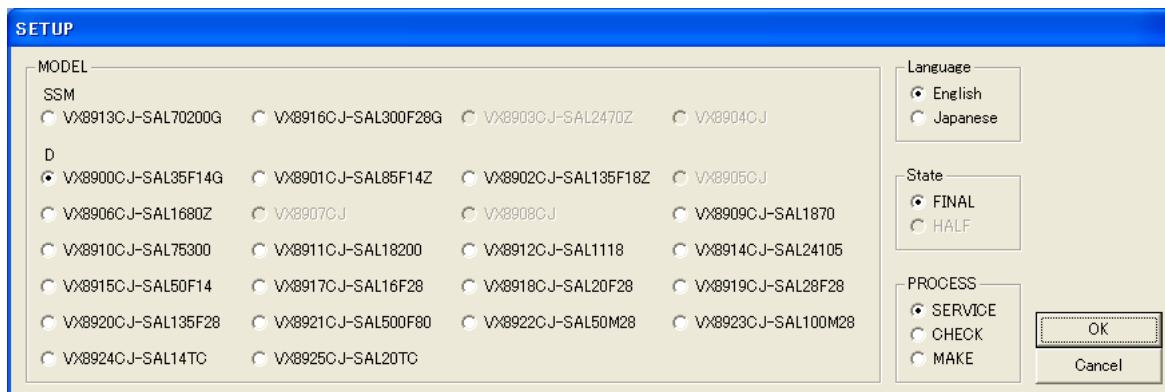


Fig.4-1-23

4-1-5. About Inspection Procedure of Lens Adjustment Program (ActuatorChecker)

The inspection method has the method of executing the method of inspecting the corresponding model as everything continues and the inspection of each item one by one.

Click **START** from the start up window when you inspect the corresponding model as everything continues.

The procedure for executing the inspection of each item one by one has been described in this manual.

4-2. APERTURE DIAMETER CHECK/ADJUSTMENT

4-2-1. Aperture Diameter Check

Equipment

- Luminance Box
- Camera DSLR-A100
- AE Master Lens
- Compact Flash (CF) Card (For image saving)
- Personal Computer (PC)
(Color Calculator 2 installed)

1. Preparations

Note: Confirm the checking lens by complete. (The adjustment of focus brush and zoom brush is completed.)

- 1) Install the CF card to the camera.
- 2) Set the equipments, camera and master lens as shown in Fig.4-2-1.

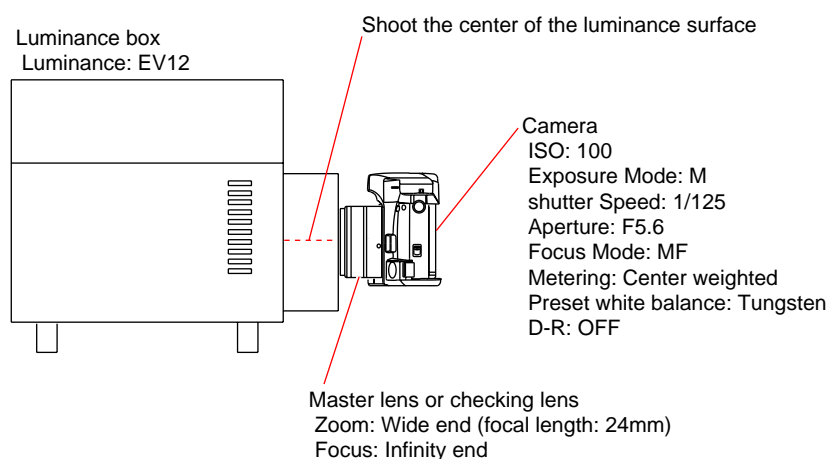


Fig.4-2-1

- 3) Shoot the images under the following conditions and save them.

Note: Shoot the center of the luminance surface three times with the master lens and checking lens.

Setting of Luminance box:

Luminance: EV11

Setting of Lens:

Zoom: Wide end (focal length: 24mm)

Focus: Infinity end

Setting of Camera:

ISO: 100

Exposure Mode: M

shutter Speed: 1/125

Aperture: F5.6

Focus Mode: MF

Metering: Center weighted

Preset white balance: Tungsten

D-R: OFF

2. Checking of Image

Note: Check the image of both master lens and checking lens.

- 1) Start the Color Calculator 2.

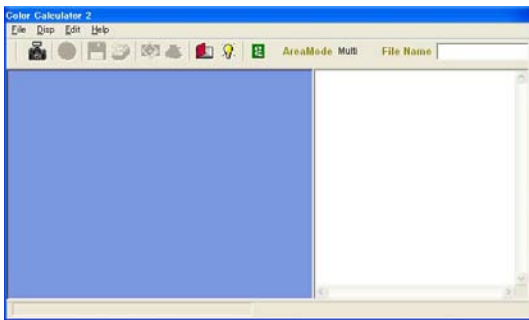


Fig.4-2-2

- 2) Read the image from the file menu.

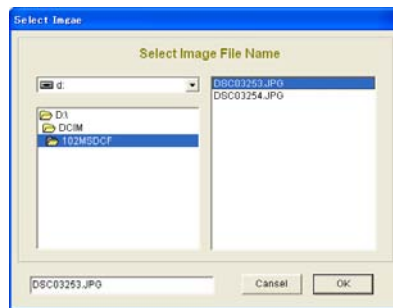
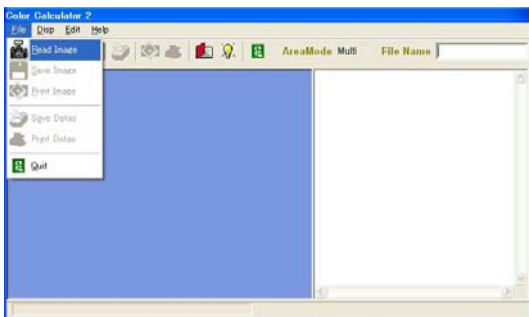


Fig.4-2-3

- 3) Set the Color Calculator 2 as follows.

Measured value display (Display menu): RGB+L*a*b*

Measuring method (Display menu): Center Single Area



Fig.4-2-4

Color space (Edit menu): sRGB



Fig.4-2-5

Area size for calculate (Edit menu → Option): 256×256 Pixels

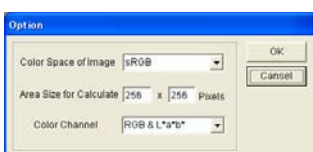


Fig.4-2-6

- 4) Click the calculate button to measure the image.
- 5) After measuring, check the “G” values.
Average “G” value of the three images shoot with master lens: (a)
Average “G” value of the three images shoot with checking lens: (b)

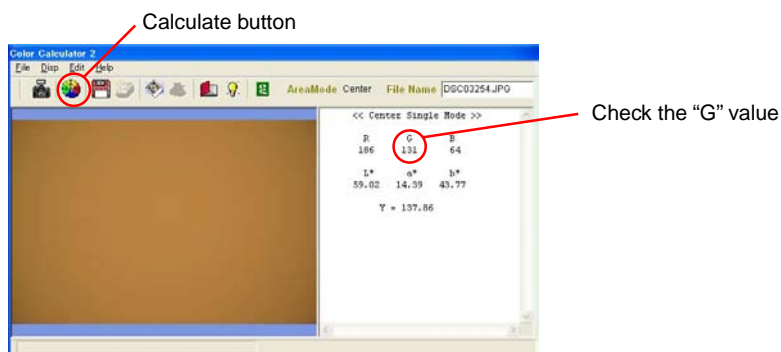


Fig.4-2-7

3. Checking Method

- 1) Calculate aperture error using the following formula, and check that the aperture error is within the specification.

$$\text{Aperture error} = \text{Average "G" value of checking lens (b)} - \text{Average "G" value of master lens (a)}$$

Specification

Aperture error = -15 to +10 (Wide end: 24mm)

- 2) When the aperture error is out of specification, perform “4-2-2. Aperture Diameter Adjustment”.

4-2-2. Aperture Diameter Adjustment

Since the iris blades remain a little in the optical path when the lens is set to the open F value, the aperture diameter changes when zoom-operated. Therefore, adjust in the procedure below.

Equipment

- Adhesive bond (B-10)
- Iris Open Fixture
- Caliper

1. Preparation

- 1) Remove the 2 group lens block from the focus cam tube block and assemble parts shown in Fig. 4-2-8 in it.
- 2) Set the zoom to 105 mm.
- 3) Attach the maximum aperture jig, and open iris .

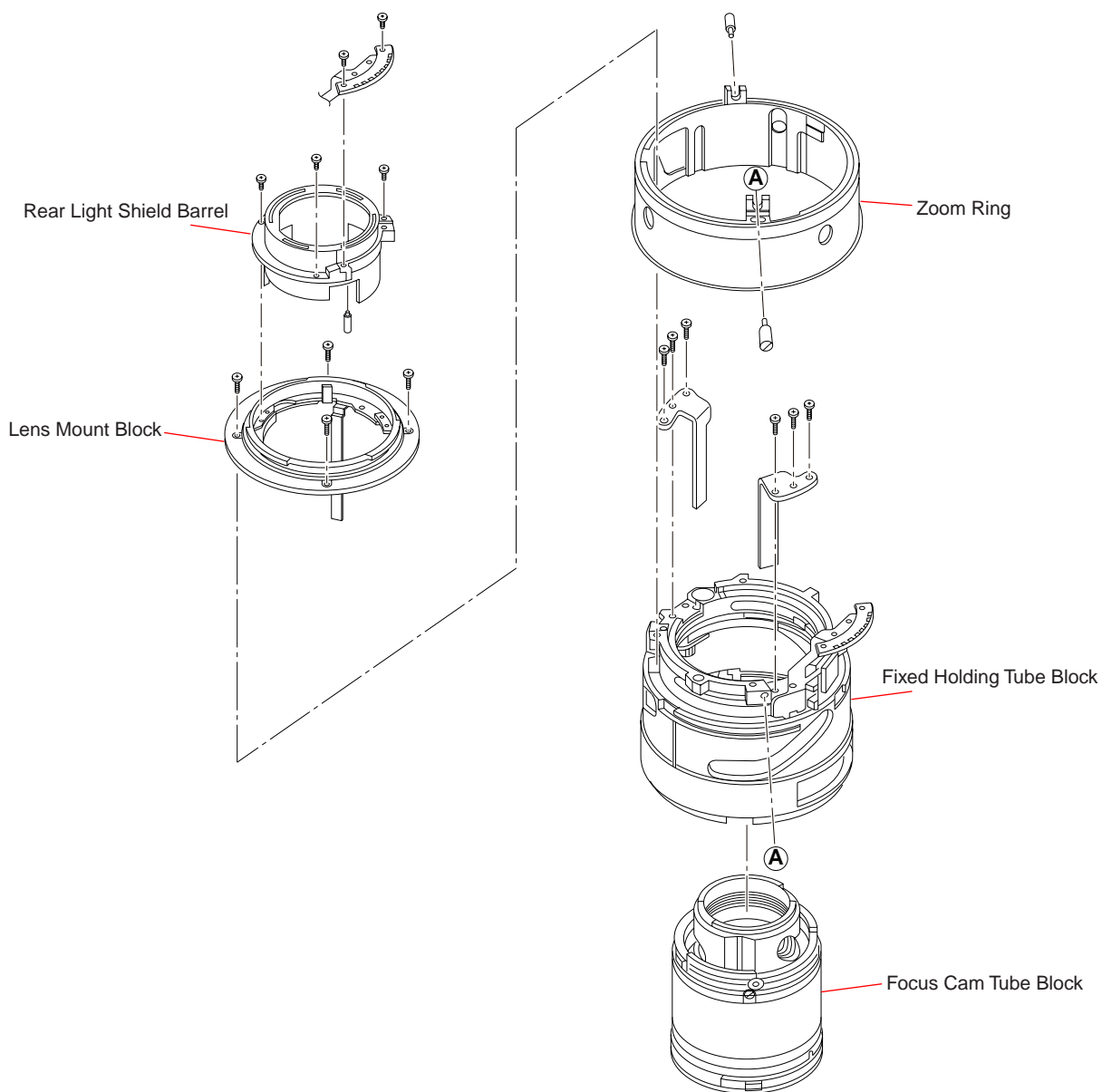


Fig.4-2-8

2. Adjustment Procedure

- 1) Adjust the diameter of inscribed circle of iris blades to about 16.6 mm by rotating the aperture blade holding ring. (Fig. 4-2-9.)
- 2) Operate the preset ring and check the shape of inscribed circle of iris blades again.
- 3) Check the tolerance of iris again and repeat the adjustment/check until the tolerance of iris meets the specification.
- 4) After completing the adjustment, apply the adhesive bond (B-10) to three indicated portions.

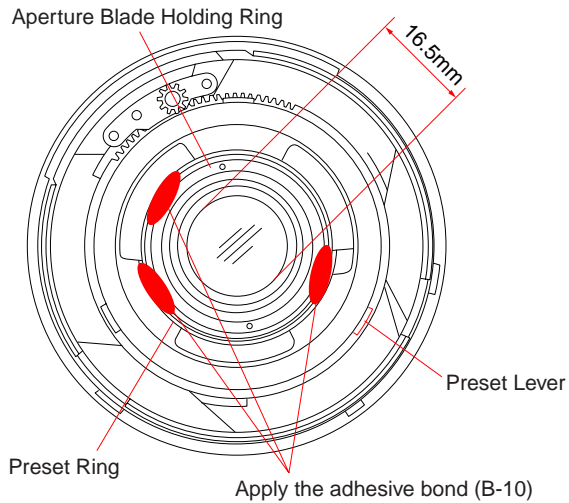


Fig.4-2-9

4-3. PROJECTIVE RESOLVING POWER CHECK/ADJUSTMENT

4-3-1. Projective Resolving Power Adjustment

Equipment

- Lens Test Projector and Variable Transformer (Output voltage: AC 100 V)

Note: Connect the variable transformer (Output voltage: AC 100 V) to the lens test projector.

- A-mount Attachment
- Screen (Art paper)
- Tape Measure
- Plane Mirror (For SLRs)

1. Preparations

Note: Check the projective resolving power of the checking lens at the following focal-length and distance.

Focal-length f (mm)	distance (m)
24	1.1
50	2.0
105	4.0

Table 4-3-1

- 1) Perform the following steps (1) to (3), and incorporate the internal lenses of the lens test projector according to the checking focal-length.

- (1) Open the lid of the lens test projector.
- (2) Pull up and turn the fixed levers on the right and left sides of the lens test projector.
- (3) Remove or insert the lens.

Note: Be sure to have the right position and direction of the lens.

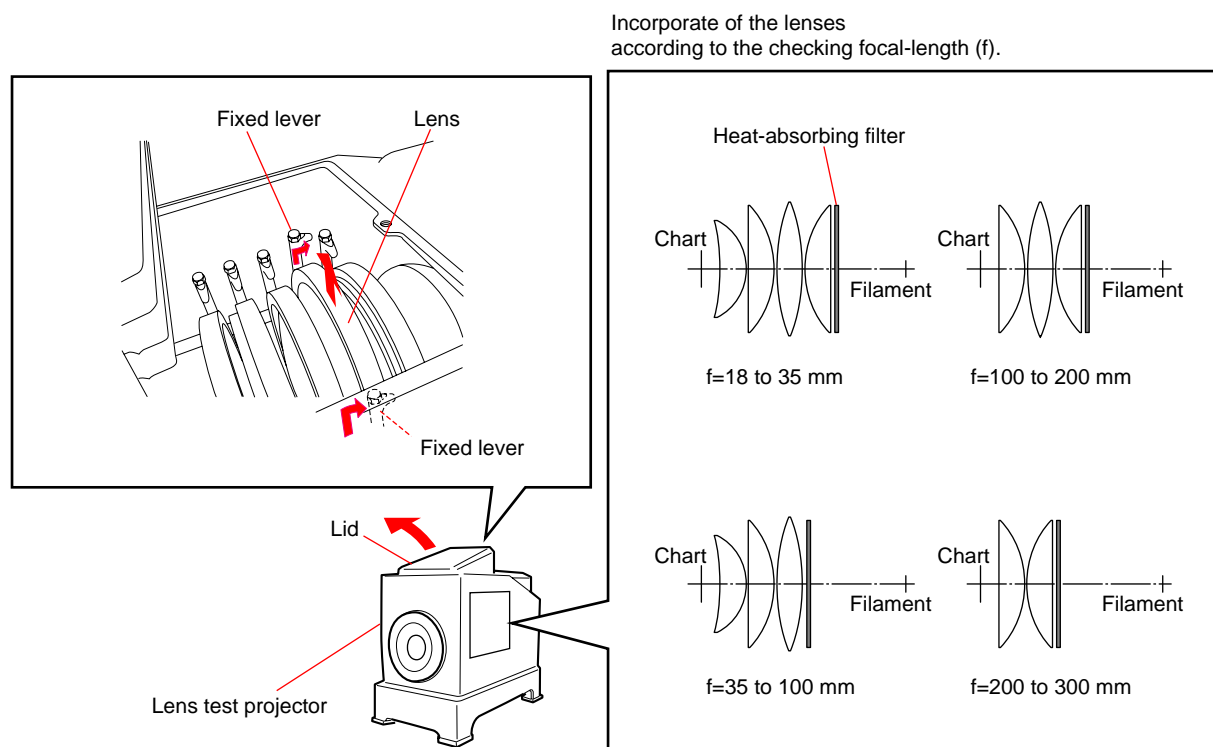


Fig.4-3-1

- 2) Attach the checking lens to the lens test projector, and set the equipments as shown in Fig.4-3-2.
- 3) Turn the fan switch of the lens test projector to ON, then turn the lamp switch to ON.

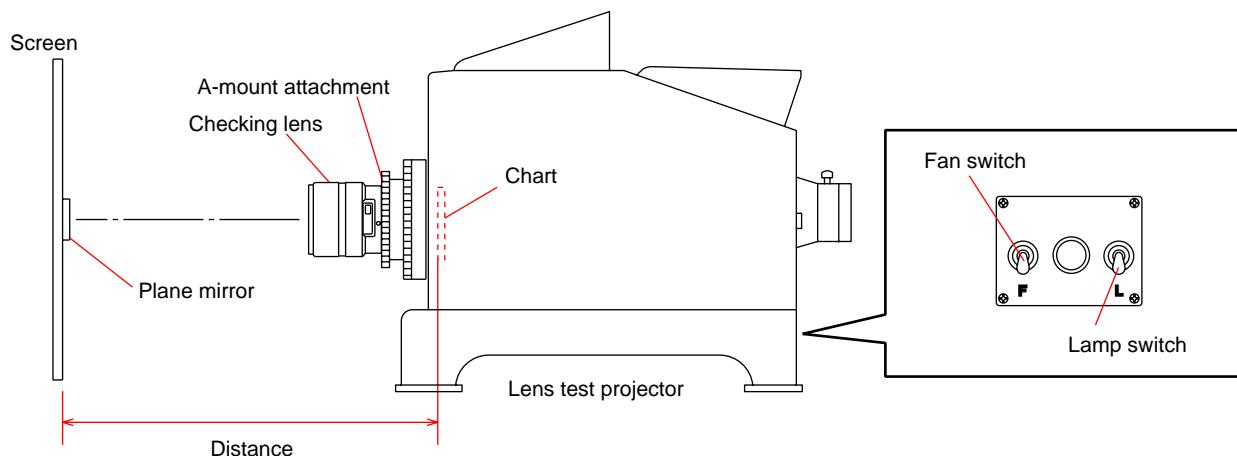


Fig.4-3-2

- 4) Turn the focus ring of the checking lens until the chart image projected on the screen is the sharpest at the center ($y'=0$).
- 5) Set the plane mirror to the center of the projected image ($y'=0$), and adjust the projector position so that the mirror reflects the light to the center of the lens.

2. Checking Method

- 1) Turn the focus ring of the checking lens until the chart image projected on the screen is the sharpest at the center ($y'=0$).
- 2) Read the number of the smallest pitched lines at the center ($y'=0$).

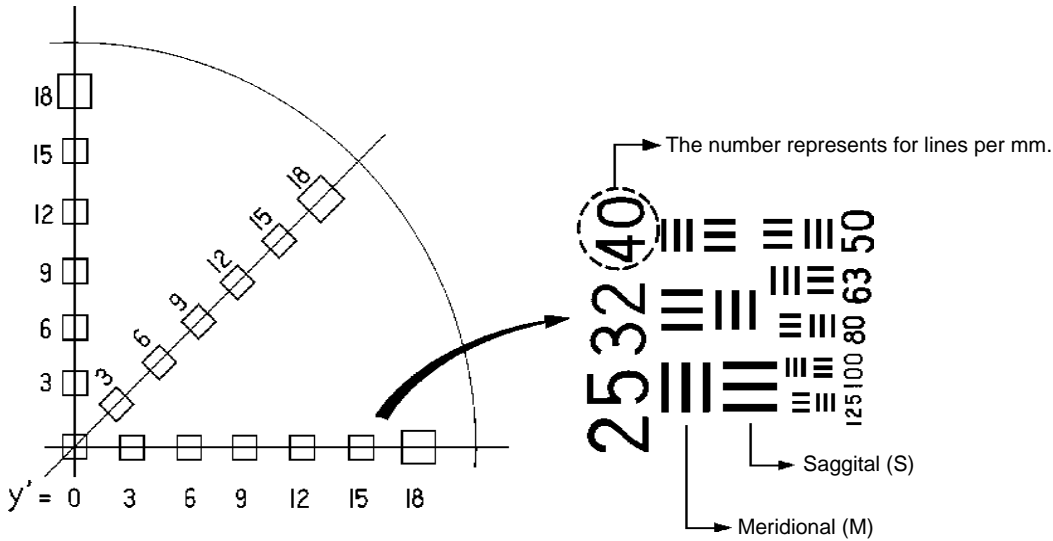


Fig.4-3-3

- 3) Turn the mount rotation ring of lens test projector until the projected image at a certain peripheral point ($y'=15$ or 18) on the screen appears the most unsharp.

Read the number of the smallest pitched lines (both saggital and meridional: 3 lines) at the peripheral point.

Note: When reading the number of the smallest pitched lines, be careful of the spurious resolution.

Spurious resolution is the reversed image of 2 or 4 lines which appears on screen when focus is beyond maximum revolving power.

Do not confuse spurious resolution for the smallest pitched lines.

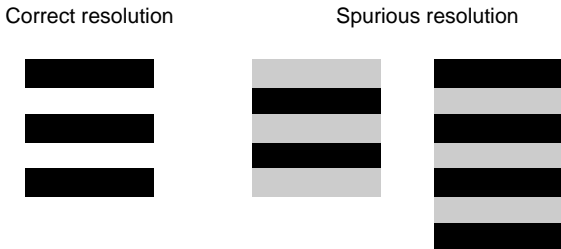


Fig.4-3-4

- 4) Change the focal-length (zoom) and distance of the checking lens, and check that the all readings ($y'=0$, $y'=12$ ($f=24$, meridional (M) only) saggital (S) and meridional (M) at $y'=15$ or 18) at each focal-length (zoom) and distance is within the specification of the Table 4-3-2.

Specification

Focal-length f (mm)	distance (m)	Number of the smallest pitched lines						
		Center ($y'=0$) (Lines per mm)	$y'=12$ (Lines per mm)		$y'=15$ (Lines per mm)		$y'=18$ (Lines per mm)	
			S	M	S	M	S	M
24	1.1	125 or greater	—	25 or greater	40 or greater	32 or greater	25 or greater	25 or greater
50	2.0	125 or greater	—	—	40 or greater	32 or greater	40 or greater	25 or greater
105	4.0	125 or greater	—	—	40 or greater	25 or greater	40 or greater	25 or greater

Table 4-3-2

4-3-2. Projective Resolving Power Check

- Note:**
- Check the projective resolving power. If it does not meet the specification, adjust the projective resolving power.
 - The following projective resolving power adjustments 1 and 2 meet the specifications respectively.

1. Projective Resolving Power (Warp) Adjustment

Check the projective resolving power. Confirm whether the focused point should locate in front or at back of the focused peripheral points, and adjust.

- 1) Set the focal length of lens to 105 mm and adjust the focus so that the peripheral “ $y' = 18$ ” reaches the maximum resolution.
- 2) Check the resolution of center “ $y' = 0$ ”. (Check whether it locates in front or back of the projected plane.)
- 3) According to the position of maximum resolution of center “ $y' = 0$ ”, increase or decrease the thickness of washer to adjust the interval between 3rd group and 4th group by the amount calculated by the formula below.
 - (1) If the position of maximum resolution of center “ $y' = 0$ ” locates in front, decrease the thickness of spacer adjustment washer.
 - (2) If the position of maximum resolution of center “ $y' = 0$ ” locates at back, increase the thickness of spacer adjustment washer.

$\text{Amount of thickness of adjustment washer for adjusting the space between 3rd and 4th groups} = \frac{\text{Distance (cm) measured in step 2}}{0.002}$
--

- 4) If the projective resolving power does not meet the specification, adjust again.

2. Projective Resolving Power (Partial Blur) Adjustment

Check the projective resolving power. Conform the following adjustment if necessary.

- 1) Set the focal length of lens to 105 mm and adjust the focus so that the center “ $y' = 0$ ” reaches the maximum resolution.
- 2) Check projective resolving power at reach peripheral point of “ $y' = 18$ ”.

If the projective resolving power does not meet the specification, replace the 4 group lens block.

4-4. FOCUS-SHIFT/FLANGE BACK (f'F) AND OPTICAL AXIS CHECK/ADJUSTMENT

4-4-1. Focus-shift/Flange Back (f'F) Check and Optical Axis Adjustment

Equipment

- 1000 mm Collimator
- Flange Back Tester
- A-mount Attachment
- Flange Back Gauge (43.50mm)

1. Preparations

- 1) Set the equipments as shown in the Fig.4-4-1.

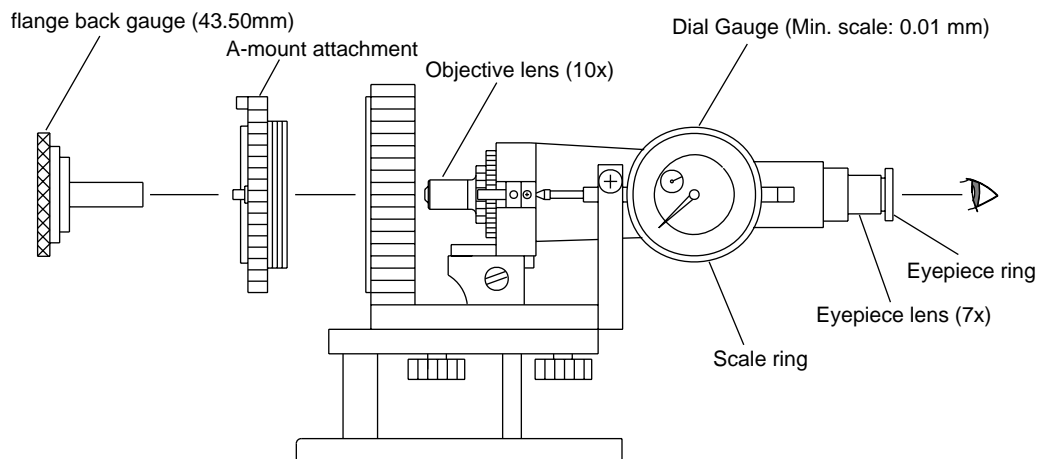


Fig.4-4-1

- 2) Looking through the eyepiece lens, turn the eyepiece ring of the flange back tester so that cross line or scale in the view is the sharpest.
- 3) Attach the flange back gauge (43.50mm) securely to the A-mount attachment and hold them together.
- 4) Turn the focusing knob of the flange back tester so that fine scratches on the flange back gauge (43.50mm) is the sharpest.

Note: Turn the knob in the direction of the arrow of Fig.4-4-2 for correct reading.

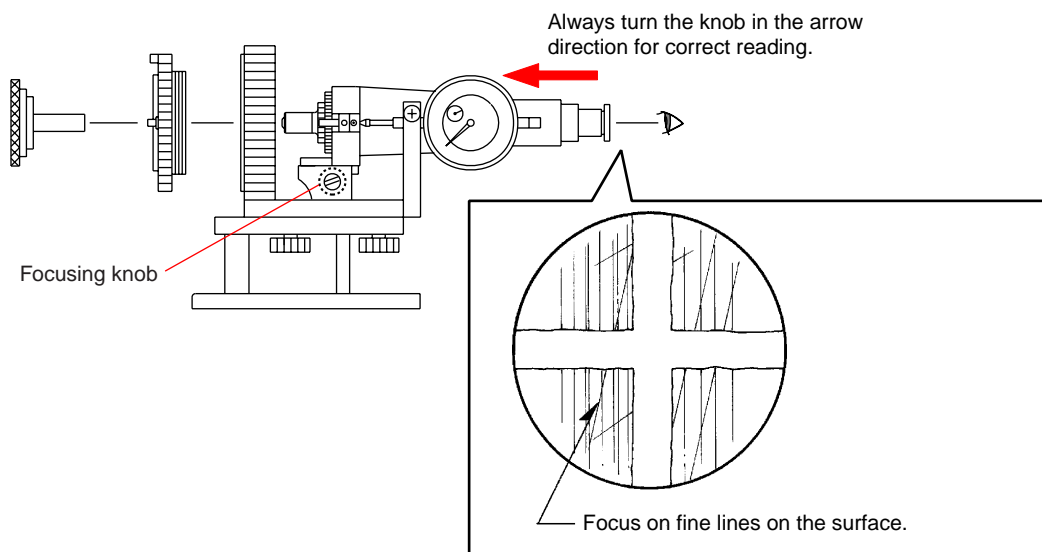


Fig.4-4-2

- 5) Turn the scale ring of the dial gauge until the long pointer indicates "0".

Note: This position is the flange back (f'F) = 43.5 mm.

Memorize the position of short-pointer.

2. Focus-shift/Flange Back (f'F) Check and Optical Axis Adjustment

- 1) Attach the checking lens to the flange back tester, and set the 1000 mm collimator.

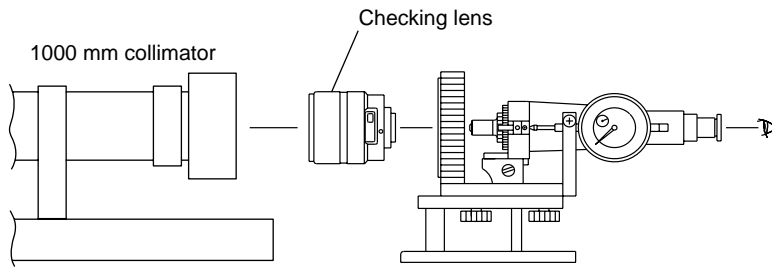


Fig.4-4-3

- 2) Set the focus ring of the checking lens to infinity end position while looking through the microscope, and align the optical axis to the center of the chart image accurately.
- 3) Turn the focusing knob of the tester until the chart image is the sharpest (red and green color areas are equal on the chart *).

*: Position in which the color of collimator chart changes from green into red and come into focus.

Also check the optical axis aligns with the chart center. (Refer to Fig.4-4-4.)

Note: Figure shows example. The cause depends on individual lens.

Optical Alignment
Best alignment

Incorrect aligned
e.g. As the focusing knob is turned, the chart may appear blurry as illustrated.
The cause depends on individual lens.

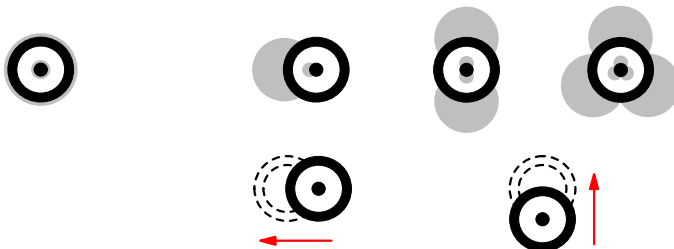


Fig.4-4-4

3. Checking Method

- 1) Calculate the flange back (f'F) of the checking lens using the following formula, and check that the specification of the Table 4-4-1 is satisfied.

$$\text{Flange back (f'F) of the checking lens} = (\text{Flange back gauge}) + (\text{Number of short-pointer revolution}) + (\text{Reading of long-pointer})$$

Specification

f (mm)	f'F (mm)
24	44.55 to 44.77
35	44.55 to 44.80
50	
70	
105	44.55 to 44.95

Table 4-4-1

- 2) When the flange back (f'F) of the checking lens is out of specification of the Table 4-4-1, perform "4-4-2. Focus-shift/Flange Back (f'F) Adjustment".

4-4-2. Flange Back (f'F) Adjustment

Equipment

- 1000 mm Collimator
- Flange Back Tester
- A-mount Attachment
- Flange Back Gauge (43.50mm)

Note: Perform the flange back value (f'F) adjustment after completing “4-4-3. Focus-Shift Adjustment”.

1. Adjustment Procedure

- 1) Perform “4-4-1. Flange back (f'F) Check” and confirm that the flange back value (f'F) of lens to be checked does not meet the specification in Table 4-4-1.
- 2) Set the focus of lens to be checked to the infinite end.
- 3) Viewing the microscope, turn the knob of flange back tester to focus.
- 4) Using the formula below, calculate the shift amount (X).

$$\text{Shift amount (X)} = f'F \text{ (measured value) with focal length "24 mm" at the infinite end} - 44.66 \text{ mm}$$

X = Shift amount to be adjusted by the back washer

- 5) According to the result in step 4), adjust the thickness of back washer

Note: Measure the thickness of back washer with a micrometer (or a caliper). (Refer to Table 4-4-2.)

- In case of negative value (-) of shift amount (X), make the back washer thinner by x.
- In case of positive value (+) of shift amount (X), make the back washer thicker by x.

Back Washer

Part No.	Description	t (mm)
2-688-527-01	WASHER (A), BACK	0.05
2-688-528-01	WASHER (B), BACK	0.07
2-688-529-01	WASHER (C), BACK	0.1
2-688-530-01	WASHER (D), BACK	0.2
2-688-531-01	WASHER (E), BACK	0.5

Table 4-4-2

- 6) Calculate thickness of coupler adjustment washer by the formula below, and replace the coupler adjustment washer.

$$\text{Thickness of coupler adjustment washer} = \text{Thickness of back washer} - 0.25 \text{ mm}$$

Coupler Adjustment Washer

Part No.	Description	t (mm)
2-684-057-01	COUPLER ADJUSTMENT WASHER	0.05
2-684-058-01	COUPLER ADJUSTMENT WASHER	0.07
2-684-059-01	COUPLER ADJUSTMENT WASHER	0.1
2-684-060-01	COUPLER ADJUSTMENT WASHER	0.2
2-684-061-01	COUPLER ADJUSTMENT WASHER	0.5

Table 4-4-3

- 7) Insert the back adjustment washer, and perform “4-4-1. Flange back (f'F) Check”.

4-5. FOCUS-SHIFT (BY ZOOMING) CHECK/ADJUSTMENT

In this section, the check and adjustment of change amount of focused point caused by the change of focal length are described.

Equipment

- 1000mm Collimator
- Flange back Tester
- A-mount Attachment
- Flange back Gauge (43.50mm)

1. Check

Note: Perform, referring to “4-4-1. Flange back Value (f’F) Check”.

- 1) Check the flange back value (f’F) at each focal length (24, 35, 50, 70, 105).
- 2) The difference between maximum and minimum values of each flange back value (f’F) is the focus-shift.

Focus-shift = Maximum value of flange back value (f’F) - minimum value of flange back value (f’F)

Note: If it does not meet the specification, adjust the focus-shift (by zooming).

Specification

f (mm)	f’F (mm)
24	44.55 to 44.77
35	44.55 to 44.80
50	
70	
105	44.55 to 44.90

Table 4-5-1

2. Adjustment

Perform, referring to the flange back (f’F) check/adjustment.

- 1) In case of completed lens, expose the body of lens by removing outer cover.
- 2) Set the focal length to 24 mm and the distance tube of lens to the infinite end. Then, measure the flange back value (f’F).
- 3) Leave the dial gauge as is, and set the focal length to 105 mm.
- 4) Loosen the screw fixing the focus stopper, and focus by rotating the manual control ring.
- 5) After adjusting, while holding the manual control ring not to rotate, set the focus stopper to the arrow direction and tighten the screw.

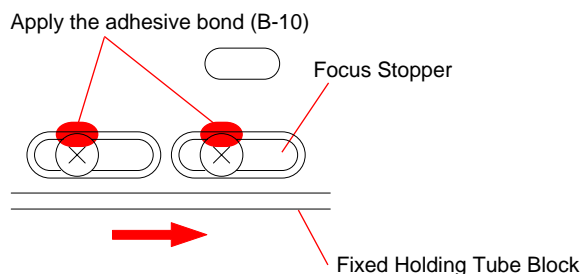


Fig.4-5-1

- 6) Repeat steps 2) to 5) until the value meets the specification.
- 7) After completing the adjustment, apply the adhesive bond (B-10) to the locations shown in the figure.

4-6. FOCUS SCALE PLATE, POSITION ADJUSTMENT

- Note:**
- The focus-shift adjustment/flange back adjustment should be completed.
 - Before focus brush ring position adjustment, be sure to perform the position adjustment of distance scale plate.

1. Adjustment

- 1) Set the focus ring tube to the infinite end.
- 2) Align the white line on the focus scale plate with the marking-off line on the fixed holding tube block.
- 3) Return a little the focus ring, and apply the adhesive bond (B-10) to the location shown in the figure.

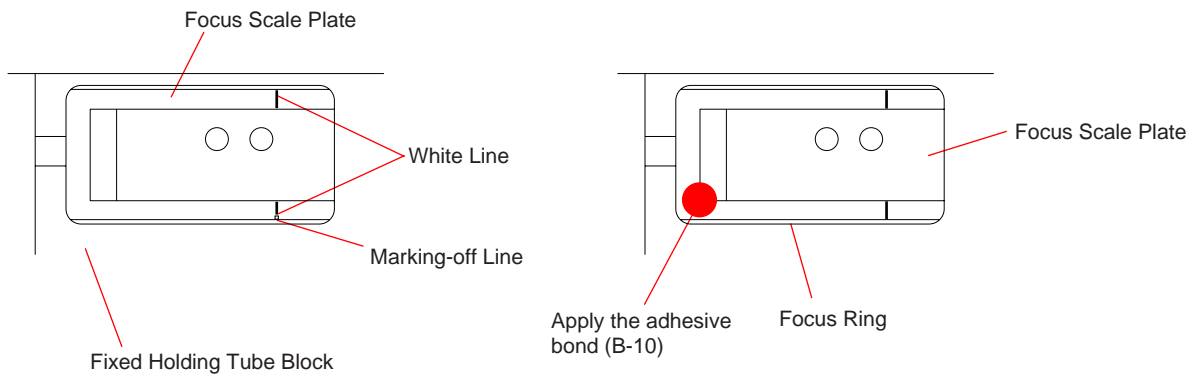


Fig.4-6-1

4-7. FOCUS-SHIFT CHECK/ADJUSTMENT (APERTURE (AMOUNT OF SPHERICAL ABERRATION))

This section describes the check/adjustment of focus-shift amount resulting change of focal-length by aperture setting.

Equipment

- 1000 mm Collimator
- Flange Back Tester
- A-mount Attachment
- Flange Back Gauge (43.50mm)
- Aberration measuring cap 62mm (SAL24105)

1. Preparations

- 1) Perform “1. Preparations” of “4-4-1. Flange Back (f’F) Check”.
- 2) Set the checking lens focus to the infinite.
- 3) Set the focal length 105mm.

2. Checking Method

- 1) Set the lens aperture to the open aperture position, and measure the flange back (f’F).
- 2) Set the aberration measuring cap 62mm (F8 equivalent) on the tip of lens as shown in the Fig.4-7-1, then measure the flange back (f’F).

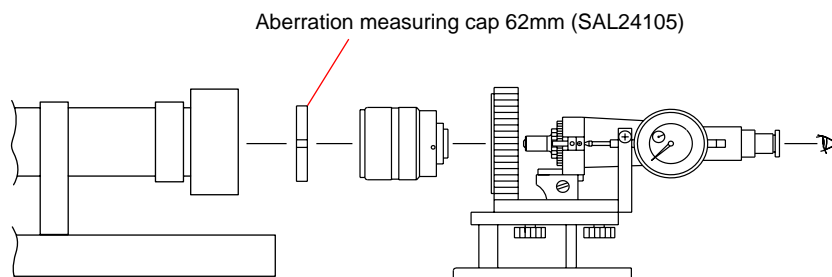


Fig.4-7-1

- 3) Calculate amount of focus-shift using the following formula, and check that the specification is satisfied.

Note: The focus-shift amount of the checking lens is difference between the flange back (f’F) of open aperture and flange back (f’F) reading (using aberration measuring cap 62mm).

$$\text{Focus-shift} = \text{Flange back (f’F) reading (using aberration measuring cap 62mm)} - \text{flange back (f’F) of open aperture reading}$$

Specification

Focus-shift (mm) = - 0.11mm to +0.13mm

4-8. LENS ROM CHECK

Equipment

- Personal Computer
- Finished Inspection JIG (AC100 V only)
- Lens Adjustment Program (ActuatorChecker.exe)

1. Preparations

- 1) Connected to equipment with checking lens. (Refer to Section 4-1-3.)
- 2) Start up of “ActuatorChecker.exe”.
- 3) Click **Set up**, and perform the initial setting. (Refer to Section 4-1-4.)

2. Checking Method

- 1) Click **ROM Data**.

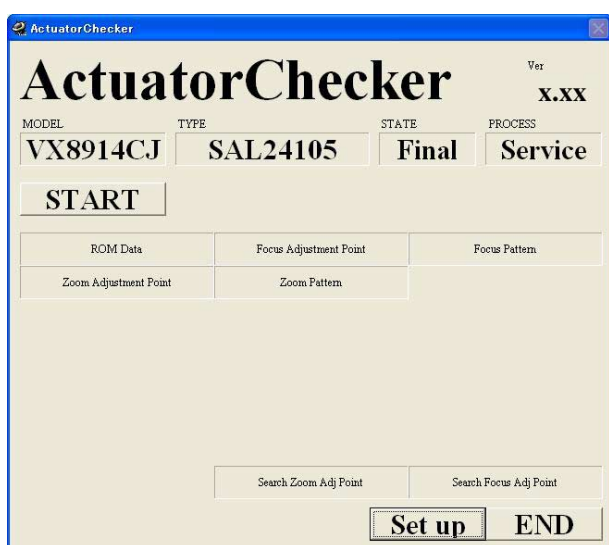


Fig.4-8-1

- 2) The Serial window appears. Input the lens serial number.

Note: When **OK** is clicked without inputting the serial number, the date executed is displayed on the completion window of each item.

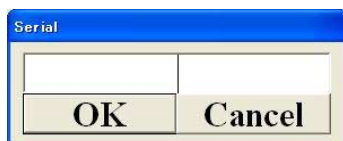


Fig.4-8-2

- 3) The message “Move FOCUS to Infinity, ZOOM to WIDE position. Then push [ENTER].” is displayed on the pop-up window. Set the focus to the infinity, zoom to wide position and press down the ENTER key.

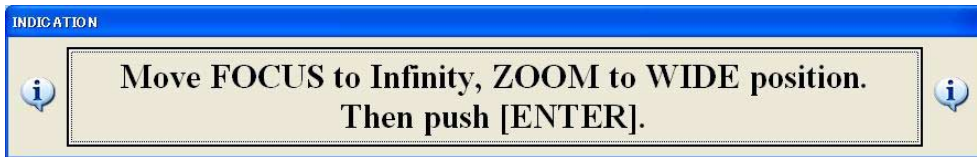


Fig.4-8-3

- 4) When “OK” is displayed on the pop-up window, press the ENTER key to return to the initial window.

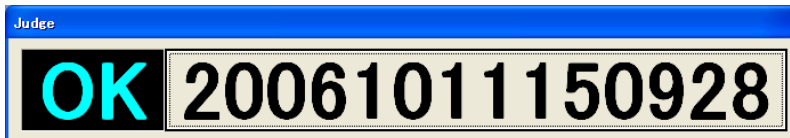


Fig.4-8-4

3. In case of error display in the ROM Data

- 1) When the error display and the NG display appear to the pop up window, press the ENTER key to return to the initial window, and perform “2. Checking Method” again.



Fig.4-8-5

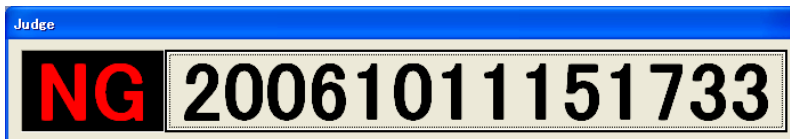


Fig.4-8-6

- 2) Although the lens is positioned at the infinity position, if the “NG” appears, confirm or perform the following.
- 4-9-1. Zoom Brush Position Adjustment (Search Zoom Adjustment Point)
 - 4-10-1. Focus Brush Position Adjustment (Search Focus Adjustment Point)
 - Cleaning of flexible pattern or the brush.
 - Replacing the brush.
 - Replacing the main flexible unit.
- 3) Perform “2. Checking Method” again, repeat the inspection until “OK” appears on the pop-up window.

4-9. ZOOM BRUSH POSITION CHECK/ADJUSTMENT AND PATTERN CHECK

4-9-1. Zoom Brush Position Adjustment (Search Zoom Adjustment Point)

Equipment

- Personal Computer (PC)
- Finished Inspection JIG (AC100 V only)
- Lens Adjustment Program

Note: Lens Adjustment Program is downloadable from the ESI homepage.

1. Preparations

- 1) Remove the zoom rubber ring.

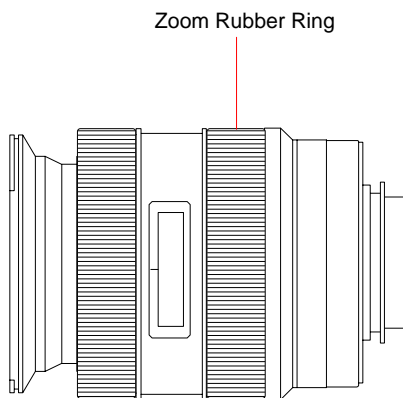


Fig.4-9-1

- 2) Peel off the polyester tape (black) 10 mm and remove the zoom ring reinforcement plate and brush cover.

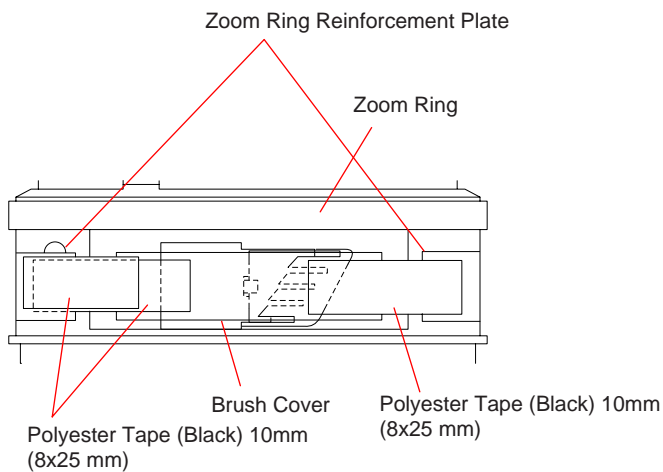


Fig.4-9-2

- 3) Connected to equipment with checking lens. (Refer to Section 4-1-3.)
- 4) Start up of "ActuatorChecker.exe".
- 5) Click **[Set up]**, and perform the initial setting. (Refer to Section 4-1-4.)

2. Adjusting Method

- 1) Set the zoom to “Tele end”.
- 2) Peel off the polyester tape (black) 10 mm.

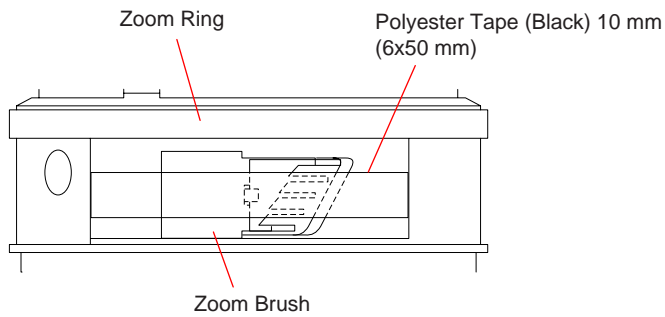


Fig.4-9-3

- 3) Click the .

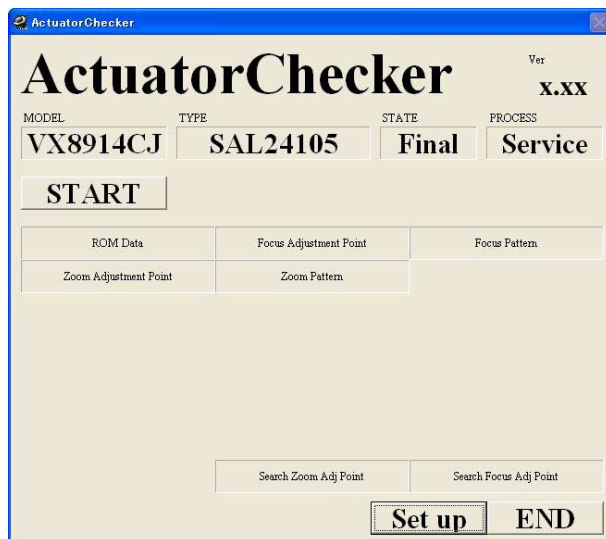


Fig.4-9-4

Note: Move the brush right and left to adjust. At this moment, be careful not to shift the position by shock when touching to the zoom.

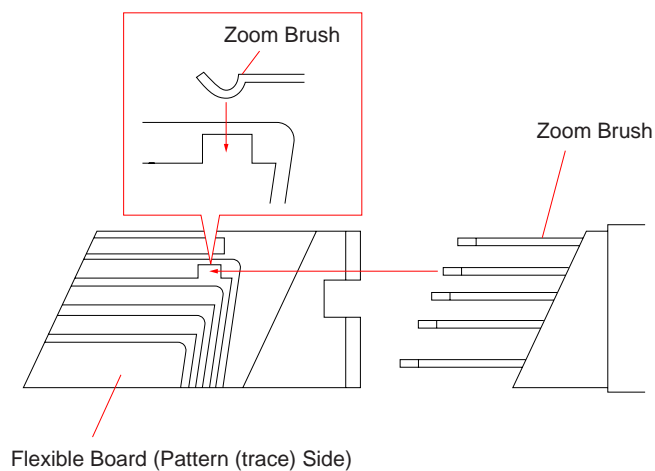


Fig.4-9-5

- 4) The message “If Zoom-Adjustment-Point is found, Buzzer sounds”. is displayed on the pop-up window. Search the position where the sound beeps by turning the lens to the infinity position.

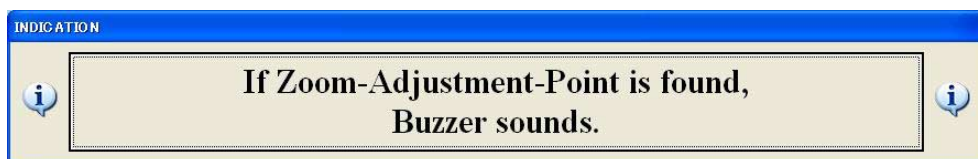


Fig.4-9-6

- 5) Fix firmly the zoom brush with the polyester tape (black) 10 mm as shown in Fig. 4-9-7.
6) Perform “4-9-2. Zoom Brush Position Check” and “4-9-3. Zoom Brush Pattern Check”

3. In case of error display in the Search Focus Adjustment Point

- 1) When the error display and the NG display appear to the pop-up window, press the ENTER key to return to the initial window, and perform “2. Adjusting Method” again.



Fig.4-9-7

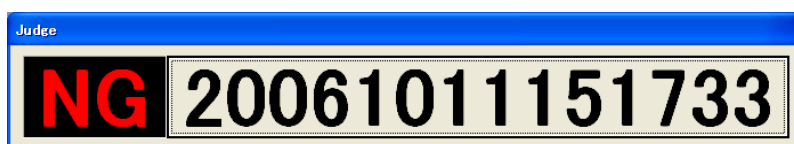


Fig.4-9-8

- 2) If the “NG” appears again, thought cause communication error of the finished inspection JIG and checking lens, confirm or perform the following.
- Improper connection of connector.
 - Improper of BL contact.
 - Disconnection of mirror box fixture.

4-9-2. Zoom Brush Position Check (Zoom Adjustment Point)

Equipment

- Personal Computer
- Finished Inspection JIG (AC100 V only)
- Lens Adjustment Program (ActuatorChecker.exe)

1. Preparations

- 1) Connected to equipment with checking lens. (Refer to Section 4-1-3.)
- 2) Start up of “ActuatorChecker.exe”.
- 3) Click **[Set up]**, and perform the initial setting. (Refer to Section 4-1-4.)

2. Checking Method

- 1) Click the **[Zoom Adjustment Point]**.

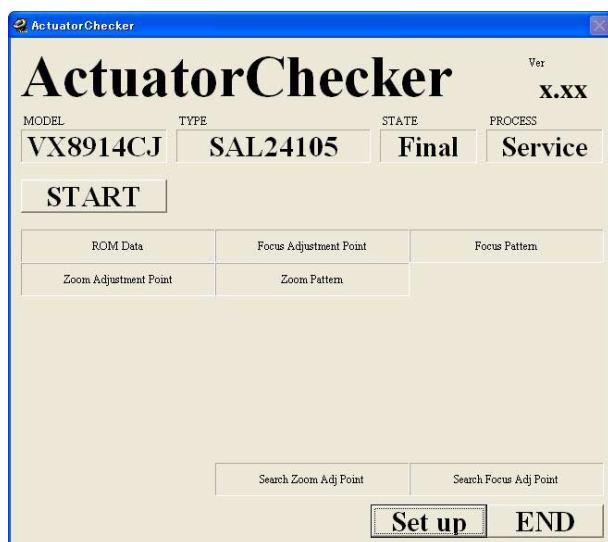


Fig.4-9-9

- 2) The Serial window appears. Input the lens serial number.

Note: When **[OK]** is clicked without inputting the serial number, the date executed is displayed on the completion window of each item.

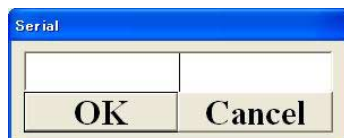


Fig.4-9-10

- 3) The message “Move ZOOM to WIDE position. Then push [ENTER].” is displayed on the pop-up window. Set the zoom to the wide position and press down the ENTER key.

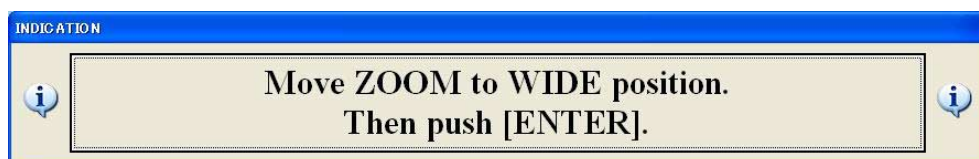


Fig.4-9-11

- 4) When the wide position check finishes normally, the message “Move ZOOM to TELE position. Then push [ENTER].” is displayed on the pop-up window.

Set the zoom to the tele position and press down the ENTER key.

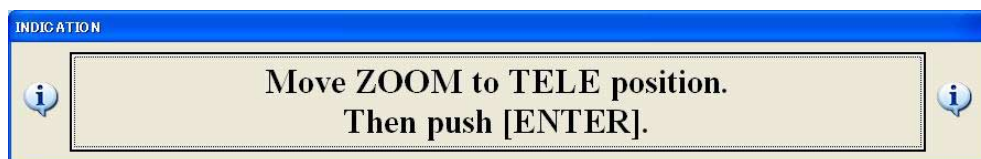


Fig.4-9-12

- 5) When the tele position check finishes normally, “OK” is displayed on the pop-up window, and press the ENTER key to return to the initial window.

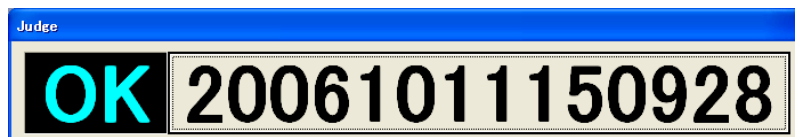


Fig.4-9-13

3. In case of error display in the Zoom Adjustment Point

- 1) When the error display and the NG display appear to the pop up window, press the ENTER key to return to the initial window, and perform “2. Checking Method” again.

- In case of error at the wide position in the Zoom Adjustment Point

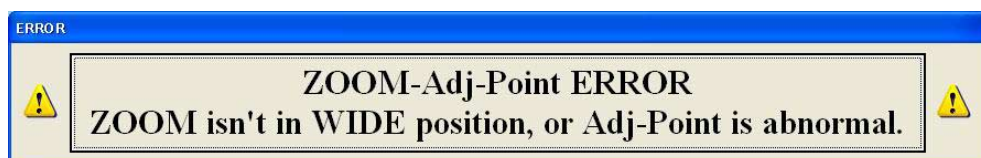


Fig.4-9-14

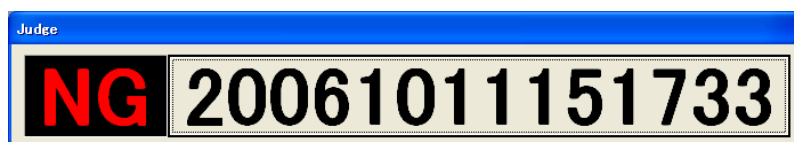


Fig.4-9-15

- In case of error at the tele position in the Zoom Adjustment Point

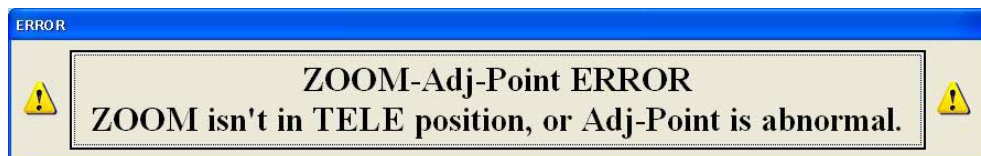


Fig.4-9-16

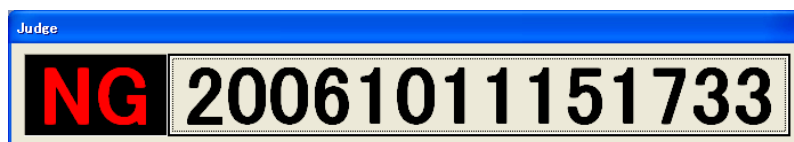


Fig.4-9-17

- 2) Although the lens is positioned at the tele position or the infinity position, if “NG” appears, confirm or perform the following.

- 4-9-1. Zoom Brush Position Adjustment (Search Zoom Adjustment Point)
- Cleaning of flexible pattern or the brush.
- Replacing the brush.

- 3) Perform “2. Checking Method” again, repeat the inspection until “OK” appears on the pop-up window.

4-9-3. Zoom Brush Pattern Check (Zoom Brush Pattern)

Equipment

- Personal Computer
- Finished Inspection JIG (AC100 V only)
- Lens Adjustment Program (ActuatorChecker.exe)

1. Preparations

- 1) Connected to equipment with checking lens. (Refer to Section 4-1-3.)
- 2) Start up of “ActuatorChecker.exe”.
- 3) Click **[Set up]**, and perform the initial setting. (Refer to Section 4-1-4.)

2. Checking Method

- 1) Click the **[Zoom Pattern]**.

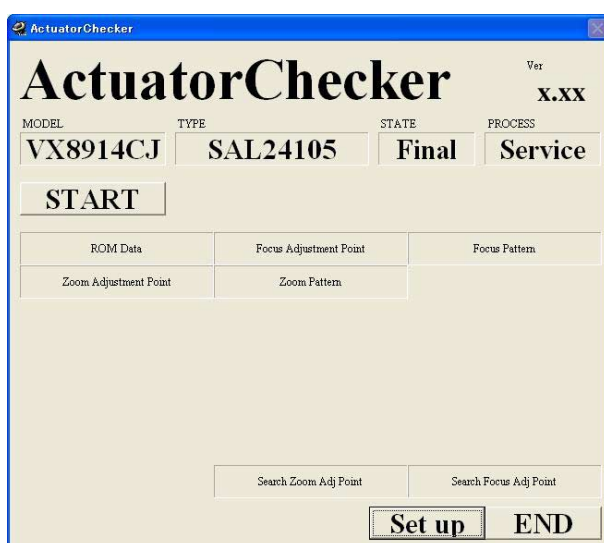


Fig.4-9-18

- 2) The Serial window appears. Input the lens serial number.

Note: When **[OK]** is clicked without inputting the serial number, the date executed is displayed on the completion window of each item.

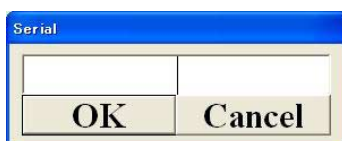


Fig.4-9-19

- 3) The message “Move ZOOM to TELE position. Then push [ENTER].” is displayed on the pop-up window. Set the zoom to the tele position and press down the ENTER key.

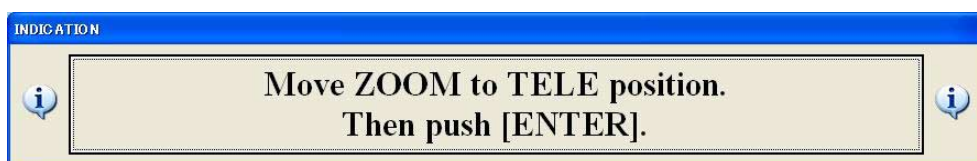


Fig.4-9-20

- 4) When the Near position check finishes normally, the message “Move ZOOM to WIDE position at about 10sec.” is displayed on the pop-up window.

Set the zoom to the wide position and press down the ENTER key.



Fig.4-9-21

- 5) When the wide position check finishes normally, the message “Reverse ZOOM to TELE position at about 10sec.” is displayed on the pop-up window.

Set the zoom to the tele position and press down the ENTER key.



Fig.4-9-22

- 6) When the infinity position check finishes normally, “OK” is displayed on the pop-up window, and press the ENTER key to return to the initial window.

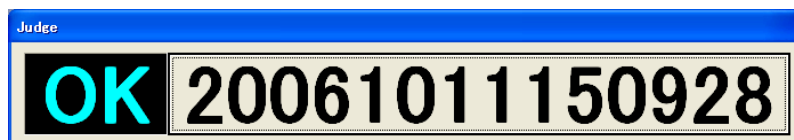


Fig.4-9-23

3. In case of error display in the Zoom Pattern (Tele position (first try))

- 1) When the error display and the NG display appear to the pop-up window, press the ENTER key to return to the initial window, and perform “2. Checking Method” again.

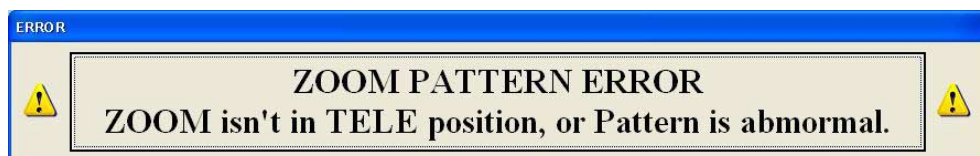


Fig.4-9-24

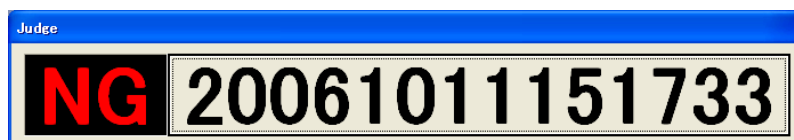


Fig.4-9-25

- 2) Although the lens is positioned at the tele position, if “NG” appears, confirm or perform the following.
- 4-9-1. Zoom Brush Position Adjustment (Search Zoom Adjustment Point)
 - Cleaning of flexible pattern or the brush.
 - Replacing the brush.
 - Rotating operation error of the focus ring (rotation speed is not suitable at a regulated speed.).
- 3) Perform “2. Checking Method” again, repeat the inspection until “OK” appears on the pop-up window.

4. In case of error display in the Zoom Pattern (WIDE position)

- 1) When the error display and the NG display appear to the pop-up window, perform the work with caution so that setting the lens to the wide position can be done in more than 5 seconds and no more than 20 seconds.
 - When the zoom pattern error



Fig.4-9-26

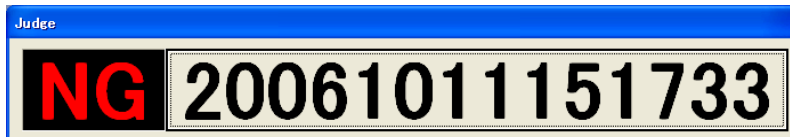


Fig.4-9-27

- When the lens does not reach the wide end infinity position seconds.

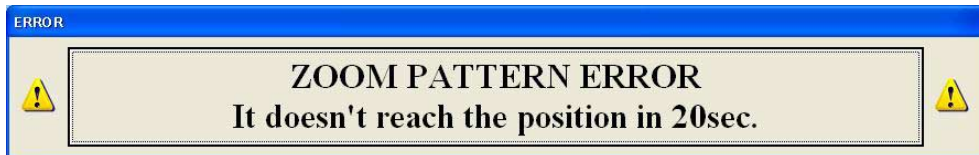


Fig.4-9-28

- 2) Perform "2. Checking Method" again, repeat the inspection until "OK" appears on the pop-up window.

5. In case of error display in the Zoom Pattern (TELE position (second try))

- 1) When the error display and the NG display appear to the pop-up window, perform the work with caution so that setting the lens to the tele position can be done in more than 5 seconds and no more than 20 seconds.
 - When the zoom pattern error



Fig.4-9-29

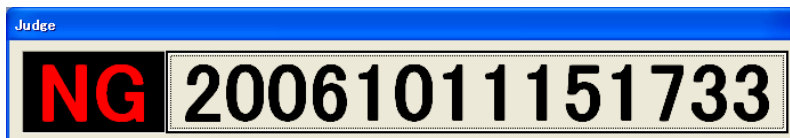


Fig.4-9-30

- When the lens does not reach the tele end infinity position seconds.

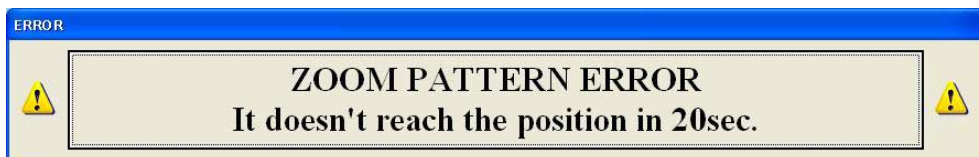


Fig.4-9-31

- 2) Perform "2. Checking Method" again, repeat the inspection until "OK" appears on the pop-up window.

4-10. FOCUS BRUSH POSITION CHECK/ADJUSTMENT AND PATTERN CHECK

4-10-1. Focus Brush Position Adjustment (Search Focus Adjustment Point)

Equipment

- Personal Computer
- Finished Inspection JIG (AC100 V only)
- Lens Adjustment Program (ActuatorChecker.exe)

1. Preparations

- 1) Remove the outer cover from the lens body.

Note: Remove the outer cover little by little, inserting the Philips screw driver in the slit portion of outer cover.

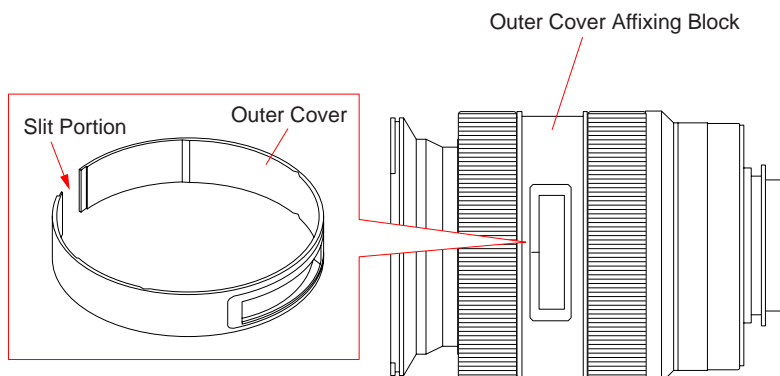


Fig.4-10-1

- 2) Connected to equipment with checking lens. (Refer to Section 4-1-3.)
- 3) Start up of “ActuatorChecker.exe”.
- 4) Click **[Set up]**, and perform the initial setting. (Refer to Section 4-1-4.)

2. Adjusting Method

- 1) Set the focus position to infinity position.
- 2) Loosen two screws fixing the brush base plate.

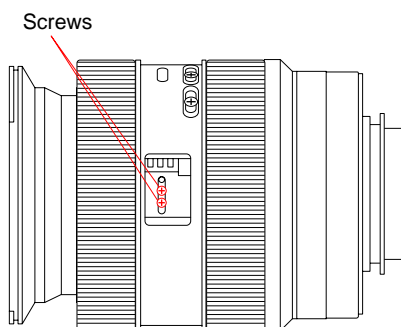


Fig.4-10-2

- 3) Click the Search Focus Adj Point.

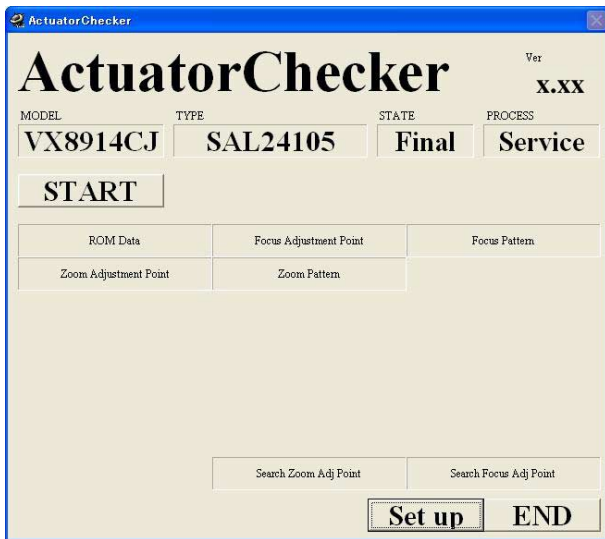


Fig.4-10-3

- 4) The message “If Focus-Adjustment-Point is found, Buzzer sounds”. is displayed on the pop-up window. Search the position where the sound beeps by turning the lens to the infinity position.



Fig.4-10-4

- 5) At the position where the sound beeps, tighten two screws loosened, apply the adhesive bond (B-10) to the screws.
- 6) Perform “4-10-2. Focus Brush Position Check” and “4-10-3. Focus Brush Pattern Check”

3. In case of error display in the Search Focus Adjustment Point

- 1) When the error display and the NG display appear to the pop-up window, press the ENTER key to return to the initial window, and perform “2. Adjusting Method” again.



Fig.4-10-5

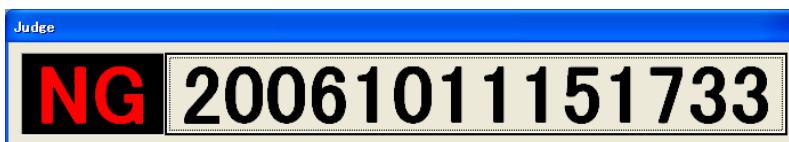


Fig.4-10-6

- 2) If the “NG” appears again, thought cause communication error of the finished inspection JIG and checking lens, confirm or perform the following.
 - Improper connection of connector.
 - Improper of BL contact.
 - Disconnection of mirror box fixture.

4-10-2. Focus Brush Position Check (Focus Adjustment Point)

Equipment

- Personal Computer
- Finished Inspection JIG (AC100 V only)
- Lens Adjustment Program (ActuatorChecker.exe)

1. Preparations

- 1) Connected to equipment with checking lens. (Refer to Section 4-1-3.)
- 2) Start up of “ActuatorChecker.exe”.
- 3) Click **[Set up]**, and perform the initial setting. (Refer to Section 4-1-4.)

2. Checking Method

- 1) Click the **[Focus Adjustment Point]**.

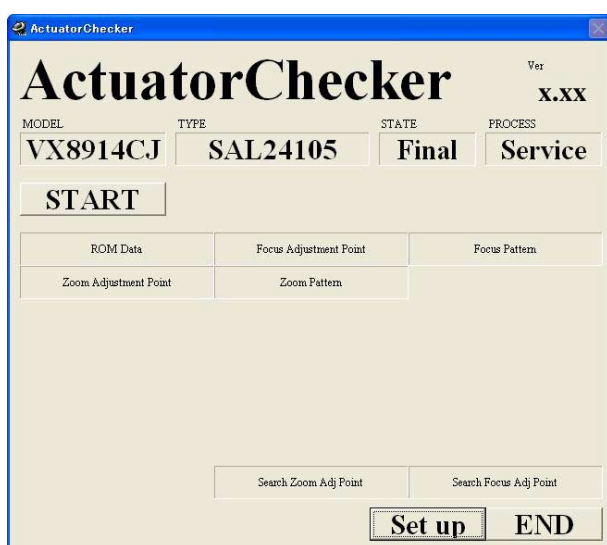


Fig.4-10-7

- 2) The Serial window appears. Input the lens serial number.

Note: When **[OK]** is clicked without inputting the serial number, the date executed is displayed on the completion window of each item.

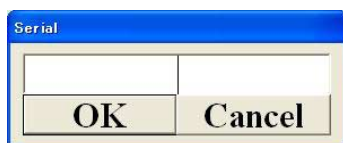


Fig.4-10-8

- 3) The message “Move FOCUS to Near position. Then push [ENTER].” is displayed on the pop-up window. Set the focus to the near position and press down the ENTER key.

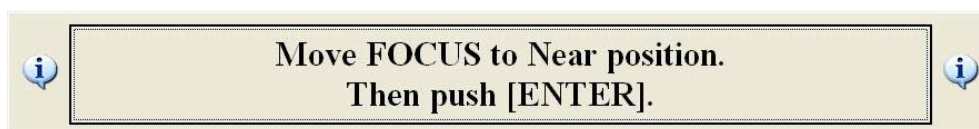


Fig.4-10-9

- 4) When the Near position check finishes normally, the message “Move FOCUS to Infinity position. Then push [ENTER].” is displayed on the pop-up window.

Set the focus to the infinity position and press down the ENTER key.

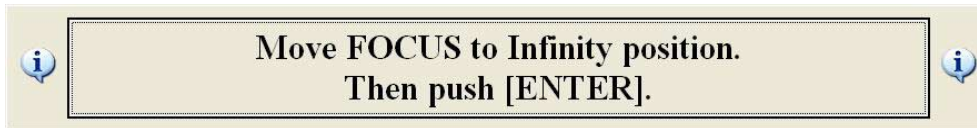


Fig.4-10-10

- 5) When the infinity position check finishes normally, “OK” is displayed on the pop-up window, and press the ENTER key to return to the initial window.

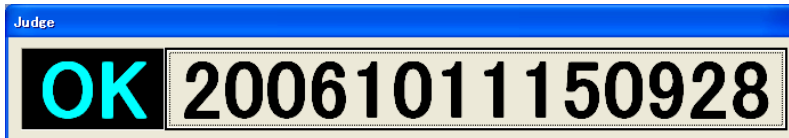


Fig.4-10-11

3. In case of error display in the Focus Adjustment Point

- 1) When the error display and the NG display appear to the pop up window, press the ENTER key to return to the initial window, and perform “2. Checking Method” again.

- In case of error at the near position in the Focus Adjustment Point

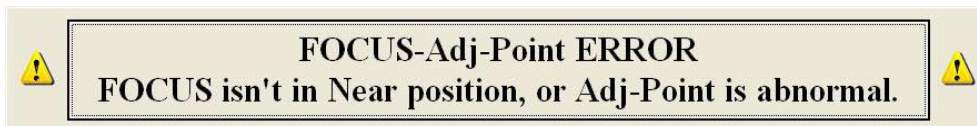


Fig.4-10-12

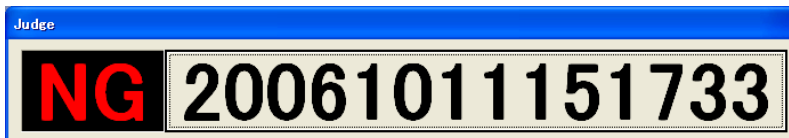


Fig.4-10-13

- In case of error at the infinity position in the Focus Adjustment Point

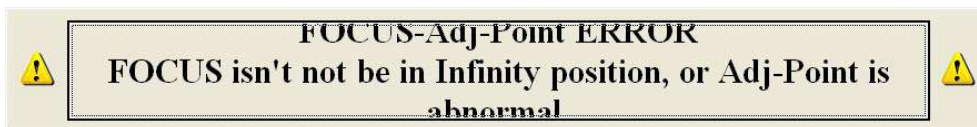


Fig.4-10-14

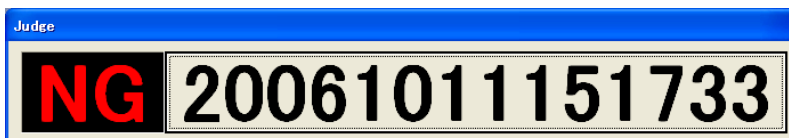


Fig.4-10-15

- 2) Although the lens is positioned at the near position or the infinity position, if “NG” appears, confirm or perform the following.
 - 4-10-1. Focus Brush Position Adjustment (Search Focus Adjustment Point)
 - Cleaning of flexible pattern or the brush.
 - Replacing the brush.
- 3) Perform “2. Checking Method” again, repeat the inspection until “OK” appears on the pop-up window.

4-10-3. Focus Brush Pattern Check (Focus Pattern)

Equipment

- Personal Computer
- Finished Inspection JIG (AC100 V only)
- Lens Adjustment Program (ActuatorChecker.exe)

1. Preparations

- 1) Connected to equipment with checking lens. (Refer to Section 4-1-3.)
- 2) Start up of “ActuatorChecker.exe”.
- 3) Click **[Set up]**, and perform the initial setting. (Refer to Section 4-1-4.)

2. Checking Method

- 1) Click the **[Focus Pattern]**.

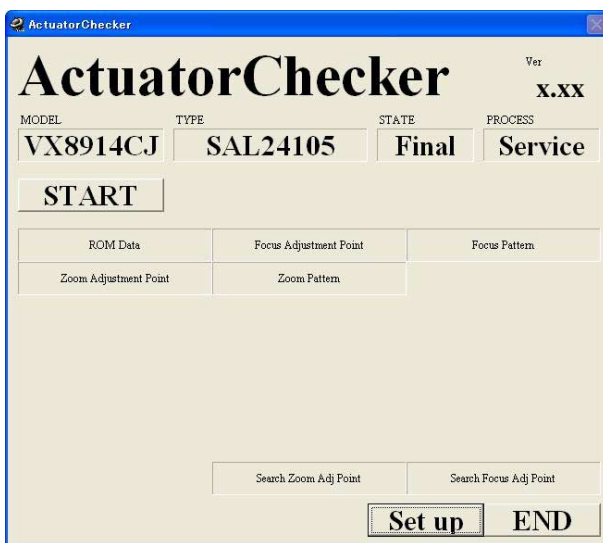


Fig.4-10-16

- 2) The Serial window appears. Input the lens serial number.

Note: When **[OK]** is clicked without inputting the serial number, the date executed is displayed on the completion window of each item.

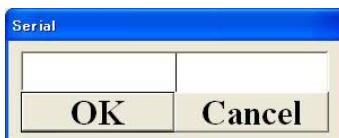


Fig.4-10-17

- 3) The message “Move FOCUS to Infinity position. Then push [ENTER].” is displayed on the pop-up window. Set the focus to the infinity position and press down the ENTER key.

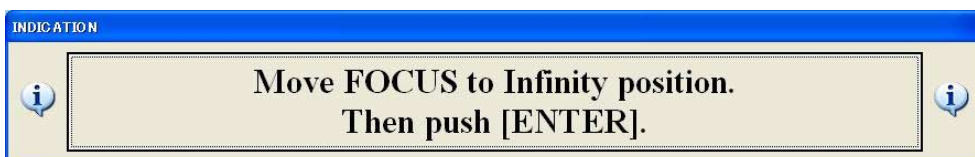


Fig.4-10-18

- 4) When the infinity position check finishes normally, the message “Move FOCUS to Near position at about 5sec.” is displayed on the pop-up window.

Set the focus to the near position and press down the ENTER key.

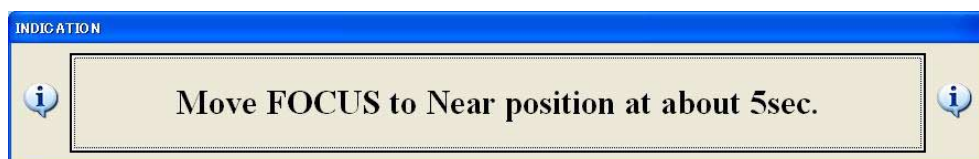


Fig.4-10-19

- 5) When the Near position check finishes normally, the message “Move FOCUS to Infinity position at about 5sec.” is displayed on the pop-up window.

Set the focus to the infinity position and press down the ENTER key.

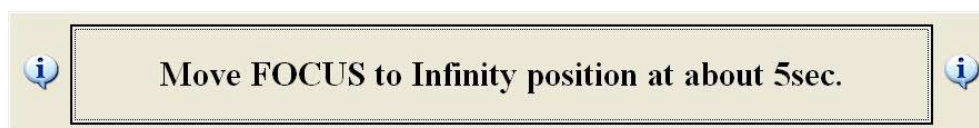


Fig.4-10-20

- 6) When the infinity position check finishes normally, “OK” is displayed on the pop-up window, and press the ENTER key to return to the initial window.

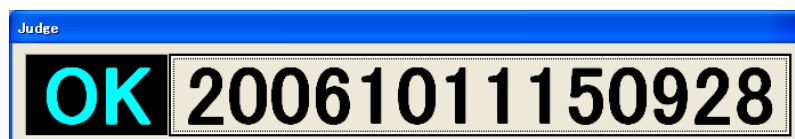


Fig.4-10-21

3. In case of error display in the Focus Pattern (infinity position (first try))

- 1) When the error display and the NG display appear to the pop-up window, press the ENTER key to return to the initial window, and perform “2. Checking Method” again.



Fig.4-10-22

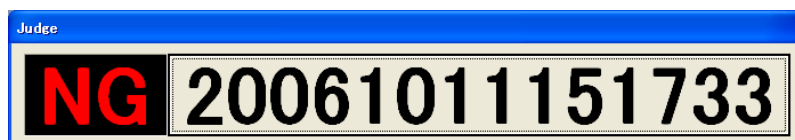


Fig.4-10-23

- 2) Although the lens is positioned at the infinity position, if “NG” appears, confirm or perform the following.
- 4-10-1. Focus Brush Position Adjustment (Search Focus Adjustment Point)
 - Cleaning of flexible pattern or the brush.
 - Replacing the brush.
 - Rotating operation error of the focus ring (rotation speed is not suitable at a regulated speed.).
- 3) Perform “2. Checking Method” again, repeat the inspection until “OK” appears on the pop-up window.

4. In case of error display in the Focus Pattern (near position)

- 1) When the error display and the NG display appear to the pop-up window, perform the work with caution so that setting the lens to the near position can be done in more than 5 seconds and no more than 20 seconds.
 - When the focus pattern error



Fig.4-10-24

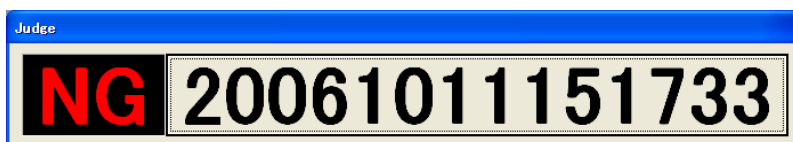


Fig.4-10-25

- When the lens does not reach the infinity end near position seconds.

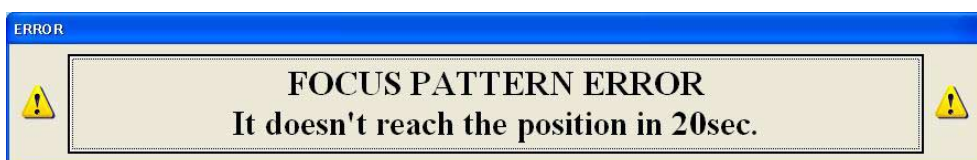


Fig.4-10-26

- 2) Perform "2. Checking Method" again, repeat the inspection until "OK" appears on the pop-up window.

5. In case of error display in the Focus Pattern (infinity position (second try))

- 1) When the error display and the NG display appear to the pop-up window, perform the work with caution so that setting the lens to the infinity position can be done in more than 5 seconds and no more than 20 seconds.
 - When the focus pattern error



Fig.4-10-27

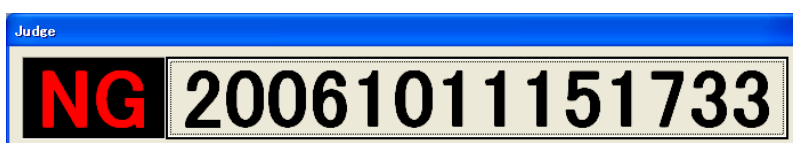


Fig.4-10-28

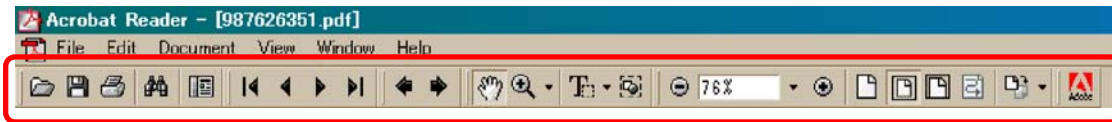
- When the lens does not reach the infinity end infinity position seconds.



Fig.4-10-29


- 2) Perform "2. Checking Method" again, repeat the inspection until "OK" appears on the pop-up window.

[Description of main button functions on toolbar of the Adobe Acrobat Reader Ver5.0 (for Windows)]




Toolbar



Printing a text

1. Click the Print button .
2. Specify a printer, print range, number of copies, and other options, and then click [OK].

Application of printing:

To set a range to be printed within a page, select the graphic selection tool  and drag on the page to enclose a range to be printed, and then click the Print button.


Reversing the screens displayed once

- To reverse the previous screens (operation) one by one, click the .
- To advance the reversed screens (operation) one by one, click the .

Application to the Service Manual:

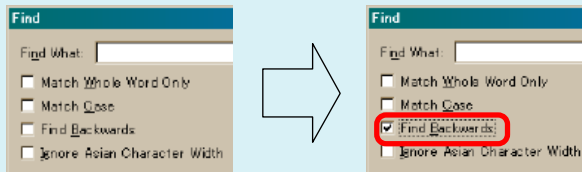
This function allows you to go and back between circuit diagram and printed circuit board diagram, and accordingly it will be convenient for the voltage check.

Finding a text

1. Click the Find button .
2. Enter a character string to be found into a text box, and click the [Find]. (Specify the find options as necessary)

Application to the Service Manual:

To execute “find” from current page toward the previous pages, select the check box “Find Backward” and then click the “Find”.








3. Open the find dialog box again, and click the [Find Again] and you can find the matched character strings displayed next. (Character strings entered previously are displayed as they are in the text box.)

Application to the Service Manual:


The parts on the drawing pages (block diagrams, circuit diagrams, printed circuit boards) and parts list pages in a text can be found using this find function. For example, find a Ref. No. of IC on the block diagram, and click the [Find Again] continuously, so that you can move to the Ref. No. of IC on the circuit diagram or printed circuit board diagram successively.


Note: The find function may not be applied to the Service Manual depending on the date of issue.

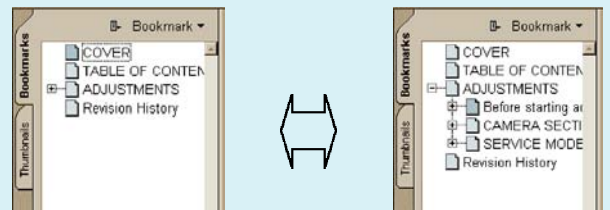
Moving with link

1. Select either palm tool , zoom tool , text selection tool , or graphic selection tool .
2. Place the pointer in the position in a text where the link exists (such as a button on cover and the table of contents page, or blue characters on the removal flowchart page or drawing page), and the pointer will change to the forefinger form .
3. Then, click the link. (You will go to the link destination.)

Moving with bookmark:



Click an item (text) on the bookmark pallet. and you can move to the link destination. Also, clicking  can display the hidden items.

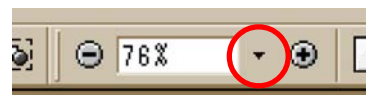
(To go back to original state, click )




Zooming or rotating the screen display

“Zoom in/out”

- Click the triangle button in the zoom control box to select the display magnification. Or, you may click  or  for zooming in or out.







“Rotate”

- Click rotate tool , and the page then rotates 90 degrees each.

Application to the Service Manual:

The printed circuit board diagram you see now can be changed to the same direction as the set.

Switching a page

- To move to the first page, click the .
- To move to the last page, click the .
- To move to the previous page, click the .
- To move to the next page, click the .

Revision History

Ver.	Date	History	Contents	S.M. Rev. issued
1.0	2006.10	Official Release	—	—
1.1	2006.12	Revised-1	<ul style="list-style-type: none"> • Change of Repair Parts (Section 1-5, Section 2, Section 3) • Change of List of Service Tools and Equipments (Section 4) • Additon of HELP46. 	Yes
1.2	2007.03	Correction-1 (C1)	<ul style="list-style-type: none"> • Correction of Repair Parts S.M Correction : Page 3-2 	Yes
1.3	2007.07	Revised-2	<ul style="list-style-type: none"> • Correction of Repair Parts (Page 3-1, 3-3, 3-6) • Change of HELP (HELP22, HELP42) • Change of Specification (Page 4-20, 4-23) • Correction of Formula (Page 4-27) 	Yes
1.4	2007.12	Revised-3	<ul style="list-style-type: none"> • Correction of Aperture Diameter Check (Page 4-13, 4-15) 	Yes
1.5	2008.03	Revised-4	<ul style="list-style-type: none"> • Addition of Repair Parts (Page 3-2, 3-6) 	Yes